

Christian Service Center
808 W. Central Blvd. Orlando, FL. 32805

REQUEST FOR BIDS

Introduction and Purpose

Christian Service Center (CSC), is requesting qualified bidders to supply and install “Security and Safety Upgrades”. Bidders will supply and install two security guard kiosks, no climb fencing surrounding our 1.8-acre campus, and sidewalk paving for access to a new gated entrance.

Bids should include the cost and installation of all materials, including all required electrical for kiosks and gating. All general conditions, overhead and administrative cost must be incorporated.

General Project Description

This is a U. S. Department of Housing and Urban Development (HUD) Community Development Block Grant (CDBG) funded project. This funding is managed locally by the City of Orlando Housing and Community Development Department and the Orange County Housing and Community Development Division, and is subject to all labor compliance laws, rules, regulations, and local ordinances.

The site of this project is located at the Christian Service Center facility at 808 West Central Blvd location in Orlando. This site houses social service programs including emergency food, clothing and hygiene programs as well as services to assist with housing, job placement and healthcare. These upgrades are required to better manage the city’s first fully comprehensive day services program serving unsheltered homeless adults.

These security additions and upgrades include a 4’x6’ enclosed security station for drive up traffic and an enclosed 4’x6’ security station for walk up clients visiting the campus. We need approximately 900 linear feet of “no climb” fencing and gates. Finally, we need to add an ADA accessible pedestrian walkway running from the Central Boulevard sidewalk to the new walk-up entrance to further establish safe and secure entryways to the campus. This project with permitting and contingency included has an estimated total cost of \$180,514.

We wish to maintain a welcoming, low-barrier-to-entry campus while at the same time adequately addressing the realities of homeless services and crisis care. The goal of the Christian Service Center is to prevent homelessness through diversion and end homelessness with Rapid Rehousing and Permanent Supportive Housing. This project is supported by City of Orlando Community Development Block Grant Public Facilities assistance to fund the structural solutions to ensure those we serve are safe while seeking these needed services.

Bids must include all costs related to the removal, replacement, and installation of new fencing and gating; all costs related to purchase and installation of security kiosks; and materials and installation of new sidewalk entryway. All general conditions, overhead and administrative cost must be incorporated into their bid.

Bidders will be provided access to the property for inspection before the due date. As a HUD

funded project, the project is subject to wage and qualification regulations. Additional documents, Federal Labor Standards Provisions, Labor Standards Compliance Letter, Personnel Participant Conditions, and the Federal Wage Decision are included with this packet. All elements of this project should comply with the Americans with Disabilities Act, Florida Law and City of Orlando Building Code Regulations.

The project is as follows:

Remove existing fencing surrounding 1.77 acre Parramore campus:

- Provide all equipment and labor for disassembling and removing approximately 800 linear feet of chain link fencing.
- Provide all equipment and labor for disassembling and removing approximately 100 linear feet of 6' wood fencing.
- Includes all disposal costs for the work described above.

Install New No Climb Fencing and gating surrounding 1.77 acre Parramore Campus:

- Furnish and install 900 linear feet of 6' black No Climb Architectural Omega Steel Fence on 3" square posts to include four 4' exit only panic gates with panic bars and hydraulic hinges and two 4' standard walk gate as well as one 12' and one 20' double drive gates.
- All posts set in heavy concrete
- One of the 4' walk-up entry gates with emergency interior release bar on N/NE portion of property between 800 and 808 West Central Blvd.
- One of the 4' walk up entry gates with emergency interior release bar on East side of 808 West Central leading into sidewalk next to main parking area
- 20' Drive up entry gate to include motorized auto opening components on East side of 808 West Central leading into main parking area.
- 12' Drive up entry gate does not need to include automatic opening components and could be a sliding or swinging gate.
- Work described above includes all necessary electrical service and connections for a functional system.
- See attachment(s) for specific materials specifications and design layout of fencing.

Furnish and Install two (2) security kiosks

- Furnish 2 pre-fabricated 4'x6' security guard kiosks (shacks) with 94" nominal height. Interior dimension from floor to ceiling should be 90".
- Install Pre-fabricated structural framing of 6063-T6 aluminum alloy extrusions.
- Furnish materials and installation of an appropriate reinforced 4"/3000psi concrete foundation similar in size to the kiosks and as recommended by manufacturer which will be fastened per manufacturer specifications.
- Install pre-fabricated kiosks to new foundation/ slab in accordance with local municipal code requirements
- Floor structure of kiosks shall be 1/8" aluminum anti-slip floor.
- Install all new electrical connections for operation of an HVAC wall mounted electric unit with fan forces operation, 9,000 BTU's cooling and 11,500 BTU's heating and thermostat in an enamel coated 20 gauge steel cabinet. The unit shall be 230/208V, 60HZ, 20AMP.

- Pre-fab units include a convenience outlet for each kiosk. HVAC unit is part of the pre-fabricated structure to be purchased. Estimated amperage needed for kiosks is 40amp.
- See attachment(s) for specific products or materials preferred and general building specifications per manufacturer.

Install approximately 300 square feet of new entryway sidewalk

- Furnish and install concrete sidewalk leading from main municipal sidewalk on Central Boulevard to new gated entrance between 800 W Central and 808 West Central to extend into the gated entry way.
- The first 20 linear feet of sidewalk will run from the Central Boulevard sidewalk to the new gate and has a slight incline from the street to the building.
- The second 30 linear feet of sidewalk runs inside the new gate along the 808 West Central Building on level ground.
- All sidewalk should be 4' thick with welded wire mesh accounting for 2500 psi.
- The walkway will comply with Americans with Disabilities Act (ADA) and local code.

Accessing Bid Documents

Bidding documents may be downloaded from the Christian Service Center's website www.christianservicecenter.org beginning Monday, April 3 2023. The documents shall be available in portable date file (.pdf) format.

Instruction to Bidders

- Sealed complete project bids are to be delivered to the following recipients no later than 1 p.m. on June 7 2023:

Kera Bigham
c/o Christian Service Center
808 West Central Boulevard
Orlando, FL. 32805

- Late bids will not be considered for acceptance.

Along with your project bid, you must include the following documentation:

- Your proposed project teams. Include names and position of each of your intended team members for this project.
- Include a proposed project schedule.
- Construction bid for fixed cost contract broken out by division. Include line-item breakdown of general conditions.
- Include what percentage of construction cost will be necessary for your payment and performance bond premium (should be required for this project)
- Except for uncontrollable and unexpected delays, CSC expects the project to be completed within three months of contracting.
- Bid Bond (5% of the bid), Payment Bond (100% bond required to contract awarded), and Performance Bond (100% bond required to contract awarded)

Bid results will be posted to the Christian Service Center website no later than June 9 2023.

Bid documents may be obtained from the following website www.christianservicecenter.org

Access to project site:

This project site is located at 808 West Central Blvd. Orlando, FL. 32805. Should you require entrance to the facility, please direct those inquires to kbigam@christianservicecenter.org and allow 24-hour response time for scheduling.

Drawings/Plans

Make sure the specifications contain all components of your project as outlined in the contractual agreement. For example, if you are installing lights, somewhere in your drawings it should show where those lights are being installed as well as the electrical panels that are being upgraded. This will be reviewed and approved by the construction manager of the Housing Department.

Sealed bids for the installation of “**Security and Safety Upgrades**” will be received by the Director of Facilities of Christian Service Center at 808 W. Central Blvd. Orlando, FL. 32805 until 2 p.m. on May 8 2023. This is a City of Orlando funded project Labor Compliance Laws, Rules, Regulations, and Ordinances may apply.

The project is as follows:

Remove existing fencing surrounding 1.77 acre Parramore campus:

- Provide all equipment and labor for disassembling and removing approximately 800 linear feet of chain link fencing.
- Provide all equipment and labor for disassembling and removing approximately 100 linear feet of 6’ wood fencing.
- Includes all disposal costs for the work described above.

Install New No Climb Fencing and gating surrounding 1.77 acre Parramore Campus:

- Furnish and install 900 linear feet of 6’ black No Climb Architectural Omega Steel Fence on 3” square posts to include four 4’ exit only panic gates with panic bars and hydraulic hinges and two 4’ standard walk gate as well as one 12’ and one 20’ double drive gates.
- All posts set in heavy concrete
- One of the 4’ walk-up entry gates with emergency interior release bar on N/NE portion of property between 800 and 808 West Central Blvd.
- One of the 4’ walk up entry gates with emergency interior release bar on East side of 808 West Central leading into sidewalk next to main parking area
- 20’ Drive up entry gate to include motorized auto opening components on East side of 808 West Central leading into main parking area.
- 12’ Drive up entry gate does not need to include automatic opening components and could be a sliding or swinging gate.
- Work described above includes all necessary electrical service and connections for a functional system.
- See attachment(s) for specific materials specifications and design layout of fencing.

Furnish and Install two (2) security kiosks

- Furnish 2 pre-fabricated 4’x6’ security guard kiosks (shacks) with 94” nominal height. Interior dimension from floor to ceiling should be 90”.
- Install Pre-fabricated structural framing of 6063-T6 aluminum alloy extrusions.
- Furnish materials and installation of an appropriate reinforced 4”/3000psi concrete foundation similar in size to the kiosks and as recommended by manufacturer which will be fastened per manufacturer specifications.
- Install pre-fabricated kiosks to new foundation/ slab in accordance with local municipal code requirements
- Floor structure of kiosks shall be 1/8” aluminum anti-slip floor.
- Install all new electrical connections for operation of an HVAC wall mounted electric unit with fan forces operation, 9,000 BTU’s cooling and 11,500 BTU’s heating and thermostat in an enamel coated 20 gauge steel cabinet. The unit shall be 230/208V, 60HZ, 20AMP.
- Pre-fab units include a convenience outlet for each kiosk. HVAC unit is part of the pre-fabricated structure to be purchased. Estimated amperage needed for kiosks is 40amp.
- See attachment(s) for specific products or materials preferred and general building

specifications per manufacturer.

Install approximately 300 square feet of new entryway sidewalk

- Furnish and install concrete sidewalk leading from main municipal sidewalk on Central Boulevard to new gated entrance between 800 W Central and 808 West Central to extend into the gated entry way.
- The first 20 linear feet of sidewalk will run from the Central Boulevard sidewalk to the new gate and has a slight incline from the street to the building.
- The second 30 linear feet of sidewalk runs inside the new gate along the 808 West Central Building on level ground.
- All sidewalk should be 4' thick with welded wire mesh accounting for 2500 psi.
- The walkway will comply with Americans with Disabilities Act (ADA) and local code.

This project is funded by the U.S. Dept. of HUD Community Development Block Grant (C.D.B.G.) from the City of Orlando. Bidders are advised to carefully review all Supplemental CONDITIONS/SPECIAL PROVISIONS and contract requirements prior to bidding and to keep complete and accurate records of all spending.

The successful low bidder and any of its subcontractors shall be responsible for complying with the Supplemental Conditions/Special provisions which are incorporated herein by reference.

Bidding documents may be downloaded from Christian Service Center.org website www.christianservicecenter.org beginning on May 3 2023. The documents shall be available in portable data file (.PDF) format.

Bidders may view the project site, located at 808 West Central Boulevard Orlando, FL. 32805, through a request to Kera Bigham at kbigham@christianservicecenter.org. Please allow 24-hour response time for scheduling.

Bidders will be required to certify, as part of their bids, that they are able to furnish labor that can work in harmony with all other elements of labor employees or be employed on the work.

The Contract is subject to Federal Wage and Hourly Laws, and minimum State wages rates as well as all other applicable labor laws. Contractor should be familiar with Davis-Bacon Act requirements.

Compliance Requirements

Article 2 – Notice of Requirement for Affirmative Action to Ensure Equal Employment Opportunity (Executive Order 11246)

Each bidder shall follow the Affirmative Action Policy as set forth in the attached Exhibit “A”. Moreover, the work to be performed is on a project assisted under a program providing direct Federal financial assistance from the Department of Housing and Urban Development and is subject to the requirements of Section 3 of the Housing and Urban Development Act of 1968, as amended, 12 U.S.C. 170u. Each contract shall include a “Section 3 Clause” in the form of Exhibit “A”.

Article 3 – Affirmative Action

Bidder shall ensure that applicants are employed, and employees are treated during employment,

without regard to their race, creed, color, or national origin.

Article 4 – Section 3 Clause

The purpose of section 3 is to ensure that employment and other economic opportunities generated by HUD assistance or HUD-assisted projects covered by section 3, shall, to the greatest extent feasible, be directed to low- and very low-income persons, particularly persons who are [recipients](#) of HUD assistance for housing.

Every effort must be made by all contractors to hire Section 3 workers for this project. A detailed spreadsheet with instructions and training will be provided prior to the approval of your Bid Packet.

Submission Deadline and Instructions

- Bids must be received by 2pm on May 8 2023 addressed to Dameon Dixon at 808 West Central Boulevard, Orlando, Florida 32805.
- Each bid will be dated, time marked and logged by Christian Service Center as received. Bids must be received at, on, or before the time and date indicated above. Bids not received at either the specified place or by the specified date and time, or both, may be rejected and returned unopened.
- Each bid must include a complete executed Bid Form in a sealed envelope marked “CHRISTIAN SERVICE CENTER SAFETY AND SECURITY UPGRADES” with the bidder’s name and address on the front by the time and date as set forth above. All bids submitted in response to the IFB will become the property of SUBRECIPIENT and may be subject to the Public Records Act, Chapter 119, Florida Statutes.
- A bidder shall not collude, consult, communicate or agree with any other bidder regarding this IFB as to any matter relating to any bid.

CHRISTIAN SERVICE CENTER reserves the right, in its sole discretion, to waive minor irregularities in a bid. A minor irregularity is a variation from the IFB that does not affect the price of the bid, give one applicant an advantage or benefit not enjoyed by other bidders, or adversely impact the interests of CHRISTIAN SERVICE CENTER.

CHRISTIAN SERVICE CENTER is the awarding authority and reserves the right to:

- Reject any and all bids.
- Waive any defects, information, and minor irregularities; to accept, in its sole discretion, exceptions to these specifications; and to award contracts or to cancel this IFB if it is in SUB RECIPIENT’S best interest to do so.

RECEIPT OF BIDS

Bids must be signed by an individual authorized to bind the bidder. No bids will be accepted after the time and date noted below. Late delivery of materials due to any type of delivery system may be cause for rejection.

Questions, Addendum or Bid Modification

Questions concerning this IFB must be submitted in writing to the sole point of contact. All questions/inquiries must be received by the sole point of contact by 1 p.m. June 5 2023 to be considered.

CHRISTIAN SERVICE CENTER will provide written answers to all timely and properly submitted written inquiries. A complete copy of all bidder questions and CHRISTIAN

SERVICE CENTER responses will be provided in an addendum to this IFB. Any agenda to this IFB will be emailed to all prospective bidders who attend the mandatory pre-bid meeting.

No changes, modifications, or additions to the bids submitted will be accepted after the submission deadline except in response to a request for clarification from SUB RECIPIENT.

Bidders with disabilities that seek reasonable accommodations, which may include the receipt of IFB information and/or addenda and/or modifications in an alternative format, must communicate such requests in writing to the contact person, and reasonable accommodation will be made by agreement with the contact person on behalf of CHRISTIAN SERVICE CENTER.

A. Completion of the Bid Form attached at Composite.

B. Statement confirming that the bidder is fully licensed to perform the project identified in this IFB and is in compliance with all state and federal laws applicable to such work. Documentation demonstrating such compliance must also be included in each and every bid package.

C. Statement that the bidder is not currently under suspension or debarment by the federal government, the State of Florida, or any other government entity.

D. Statement that neither the bidder nor any of its proposed subcontractors is on the State of Florida's convicted vendor's list or discriminatory vendor's list.

E. Statement confirming that neither the bidder, nor any of its affiliates, subsidiaries, directors, officers or employees are currently under investigation by any governmental authority and have not in the last ten (10) years been convicted or found liable for any act prohibited by law in any jurisdiction involving conspiracy or collusion with respect to bidding on any contract involving state, federal or local government funds.

G. All Contractors, subcontractors, including tiered subcontractors are subject to a non-debarment check. They must also be registered with System for Award Management (SAM.gov), be able to provide a Unique Entity Identification Number.

Christian Service Center reserves the right to reject any or all bids, to waive informalities, to advertise for new bids or proceed to do the work otherwise, as may be deemed to be in the best interest of Christian Service Center. Due Date June 7 2023, to:

Kera Bigham, Assistant Director of Operations
Christian Service Center
808 W. Central Blvd. Orlando, FL. 32805

Invitation for Bids- IFB Solicitation

Introduction and Purpose

Christian Service Center, will be installing "Security and Safety Upgrades" to our property located at 808 W. Central Blvd. Orlando, FL. 32805.

General Project Description

This is a U. S. Department of Housing and Urban Development (HUD) Community Development Block Grant (C.D.B.G) from the City of Orlando & Orange County funded project, labor compliance laws, rules, regulations, and ordinance may apply.

Project Timeline:

- **Solicitation** – April 3 2023 through June 7 2023
- **Bid Opening -Due Date/Last Day to receive bids** – 1 p.m. on June 7 2023
- **Pre – Construction Conference with Selected Bidder-** To be scheduled with selected bidder. (The pre- construction meeting with the selected bidder and the agency is mandatory. We utilize this opportunity to discuss contractor specifics pertaining to Federal Labor Compliance/Davis Bacon and answer any question that arise as well as discuss requirements for expenditure reimbursement.)
- **Project Completion Date:** August 2023 (This date is subject to change, based on availability and procurement of materials).
- **Late bids will not be considered for acceptance**

Bidders are advised that this is a federal project funded by the **Community Development Block Grant (CDBG)** and covered by **Davis-Bacon Act (DBA) and Section 3** (when assistance exceeds a threshold of \$200,000). Bidders are also advised to carefully review all SUPPLEMENTAL CONDITIONS/SPECIAL PROVISIONS and contract requirements prior to bidding.

Be aware of any DBA requirements before bidding. DBA wages must be paid, and contractor and sub(s) should include prevailing wage calculations in any bid or proposal.

The rates paid shall be not less than those contained in the enclosed Special Provisions regardless of any contractual relationship that may exist between the contractor and the workers hired to perform under the contract. For any classification of workers, the hourly rate paid must equal the sum of the base rate and the fringe benefit rates listed for that classification in the Davis-Bacon-Wage- Determination Schedule. **Paying below the wage rate and fringe benefit is not acceptable.**

Pre-award: Contractors are responsible for determining the appropriate staffing necessary to perform the contract work. Contractors are also responsible for complying with the minimum wage and benefits requirements for each classification performing work on the contract. If a classification considered necessary by the contractor for performance of the work is not listed on the applicable wage determination, the contractor must initiate a request for approval of an additional classification along with the proposed wage and benefit rates for that classification.

Section 3 HUD Act of 1968: Economic opportunity shall, *to the greatest extent feasible*, be directed to low- and very low-income residents and business in that area. All Section 3 covered contract in excess of \$200,000 are subject to the Section 3 Clause, verbatim found at 24 CFR Part 75. Contractors and subcontractors that perform any work under a Section 3 covered contract for any federal project are required to comply with the Section 3 regulations. Section 3 applies to an entire project, regardless of whether the project is fully or partially assisted under HUD program that provide housing and community development financial assistance.

Preference for Section 3 Business Concerns. Preference in the award of Section 3 covered

contracts that are awarded under a sealed bid process shall be provided as follows: Bids shall be solicited from all businesses (Section 3 business concerns, and non-Section 3 business concerns). An award shall be made to the qualified Section 3 business concern with the highest priority ranking and with the lowest responsive bid. If no responsive bid by a Section 3 business concern meets these requirements, the contract shall be awarded to a responsible bidder with the lowest responsive bid.

Selected contractor shall be required to provide **active status** for the following entities: SAM.gov registration, SUNBIZ.org and Florida DBPR (contractor's license) for the same business entity in compliance with State and Federal requirements prior to execution of Construction Contract.

Selected bidder shall provide to the Agency and Orange County Program Administrator a copy of all executed contracts with any sub-contractors, and tiered subcontractors all of which shall include Orange County Special Provisions requiring the respective sub-contractor or tiered sub to comply with the requirements of the Uniform Administrative Requirements and 2 CFR Part 200 Appendix II.

Selected bidder shall not enter into any Subcontract with any person or firm debarred from Government contracts pursuant to Executive Order 11246 and that it follows the requirements of 2 C.F.R. Part 180. Neither it, its principals, nor its subcontractors are presently debarred, suspended, proposed for debarment, declared ineligible, or voluntarily excluded from participation in this transaction by any federal department or agency.

ADVERTISEMENT FOR BIDS

Christian Service Center Corporate address: 808 West Central Blvd, Orlando FL 32805

Separate sealed bids for Christian Service Center "Security of Safety Upgrades" project will be received by Property Manager Kera Bigham at the work site/corporate address until June 7 1pm, and then officially opened and read aloud at said office. Project includes fencing, security kiosks and limited hardscape.

The information for Bidders, Form of Bid, Form of Contract, plans, specifications, and Forms of Bid Guarantee and other documents may be examined, and copies obtained at project address: 808 West Central Blvd, Orlando FL 32805. We will host a pre-bid walkthroughs by appointment. Please contact kbigham@christianservicecenter.org to schedule onsite walkthrough.

The owner reserves the right to waive any information or to reject any or all bids and must receive a minimum of three (3) qualified bids to award the contract.

Contractors that are eligible to submit a bid include those contractors who: maintain and can provide proof of applicable state professional license and local business license, maintain and can provide proof of Liability and Workers Comp insurance.

Minimum Bid Requirements – 3 Bids Required or Proof of Efforts to Solicit Contractors

This can be emails sent to solicit contractors for your project or other efforts submitted with our Bid Packets.

Applicability

The Project or Program to which the construction work covered by this contract pertains is being assisted by the United States of America and the following Federal Labor Standards Provisions are included in this Contract pursuant to the provisions applicable to such Federal assistance.

A. 1. (i) **Minimum Wages.** All laborers and mechanics employed or working upon the site of the work, will be paid unconditionally and not less often than once a week, and without subsequent deduction or rebate on any account (except such payroll deductions as are permitted by regulations issued by the Secretary of Labor under the Copeland Act (29 CFR Part 3), the full amount of wages and bona fide fringe benefits (or cash equivalents thereof) due at time of payment computed at rates not less than those contained in the wage determination of the Secretary of Labor which is attached hereto and made a part hereof, regardless of any contractual relationship which may be alleged to exist between the contractor and such laborers and mechanics. Contributions made or costs reasonably anticipated for bona fide fringe benefits under Section 1(b)(2) of the Davis-Bacon Act on behalf of laborers or mechanics are considered wages paid to such laborers or mechanics, subject to the provisions of 29 CFR 5.5(a)(1)(iv); also, regular contributions made or costs incurred for more than a weekly period (but not less often than quarterly) under plans, funds, or programs, which cover the particular weekly period, are deemed to be constructively made or incurred during such weekly period.

Such laborers and mechanics shall be paid the appropriate wage rate and fringe benefits on the wage determination for the classification of work actually performed, without regard to skill, except as provided in 29 CFR 5.5(a)(4). Laborers or mechanics performing work in more than one classification may be compensated at the rate specified for each classification for the time actually worked therein: Provided, That the employer's payroll records accurately set forth the time spent in each classification in which work is performed. The wage determination (including any additional classification and wage rates conformed under 29 CFR 5.5(a)(1)(ii) and the Davis-Bacon poster (WH-1321) shall be posted at all times by the contractor and its subcontractors at the site of the work in a prominent and accessible, place where it can be easily seen by the workers.

(ii) (a) Any class of laborers or mechanics which is not listed in the wage determination and which is to be employed under the contract shall be classified in conformance with the wage determination. HUD shall approve an additional classification and wage rate and fringe benefits therefor only when the following criteria have been met:

(1) The work to be performed by the classification requested is not performed by a classification in the wage determination; and

(2) The classification is utilized in the area by the construction industry; and

(3) The proposed wage rate, including any bona fide fringe benefits, bears a reasonable relationship to the wage rates contained in the wage determination.

(b) If the contractor and the laborers and mechanics to be employed in the classification (if known), or their representatives, and HUD or its designee agree on the classification and wage rate (including the amount designated for fringe benefits where appropriate), a report of the action taken shall be sent by HUD or its designee to the Administrator of the Wage and Hour Division, Employment Standards Administration, U.S. Department of Labor, Washington, D.C. 20210. The Administrator, or an authorized representative, will approve, modify, or disapprove every additional classification action within 30 days of receipt and so advise HUD or its designee or will notify HUD or its designee within the 30-day period that additional time is necessary. (Approved by the Office of Management and Budget under OMB control number 1215-0140.)

(c) In the event the contractor, the laborers or mechanics to be employed in the classification or their representatives, and HUD or its designee do not agree on the proposed classification and wage rate (including the amount designated for fringe benefits, where appropriate), HUD or its designee shall refer the questions, including the views of all interested parties and the recommendation of HUD or its designee, to the Administrator for determination. The Administrator, or an authorized representative, will issue a determination within 30 days of receipt and so advise HUD or its designee or will notify HUD or its designee within the 30-day period that additional time is necessary. (Approved by the Office of Management and Budget under OMB Control Number 1215-0140.)

(d) The wage rate (including fringe benefits where appropriate) determined pursuant to subparagraphs (1)(ii)(b) or (c) of this paragraph, shall be paid to all workers performing work in the classification under this contract from the first day on which work is performed in the classification.

(iii) Whenever the minimum wage rate prescribed in the contract for a class of laborers or mechanics includes a fringe benefit which is not expressed as an hourly rate, the contractor shall either pay the benefit as stated in the wage determination or shall pay another bona fide fringe benefit or an hourly cash equivalent thereof.

(iv) If the contractor does not make payments to a trustee or other third person, the contractor may consider as part



Date: December 2, 1996

(Rev 1) Letter No. LR-96-01

- Subject: **Labor standards compliance requirements for self-employee laborers and mechanics (aka Working Subcontractors)**
- I. **HUD policy on prevailing wage applicability.**
 - II. **Compliance and certification parameters.**
 - III. **Owners of businesses working with their crews.**
 - IV. **Owner-Operators of power equipment.**
 - V. **Truck drivers.**

The Federal prevailing wage requirements and compliance standards for self-employed laborers and mechanics (also referred to as "working subcontractors") have long been a confusing and contentious area for the Department of Labor (DOL), HUD, the Internal Revenue Service and contractors and subcontractors.

The following policy represents an effort to provide practical guidance for field application. The guidance more specifically concerns the wage certification requirements for self-employed mechanics and laborers on projects subject to Federal labor standards provisions including Davis-Bacon and HUD-determined maintenance and nonroutine maintenance prevailing wage rate determinations. This policy does not attempt to establish whether working subcontractors are subject to Federal labor standards nor whether such working subcontractors are *bona fide*. The clear meaning of statutory provisions and regulatory definitions does not require further examination of applicability. Additionally, statutory and regulatory language are clear that the question of whether certain self-employed laborers and mechanics are *bona fide* subcontractors is not germane to the issue of prevailing wage standard applicability¹.

I. HUD policy on prevailing wage applicability.

The Davis-Bacon Act (DBA), HUD program Related Acts (DBRA) concerning the payment of prevailing wages as determined by the Secretary of Labor, and the U.S. Housing Act of 1937 concerning the payment of prevailing wage rates established by HUD provide that the wage protections afforded in these statutes apply to laborers and mechanics employed on the covered work. The DBA and DBRA implementing regulations (29 CFR Part 5) specifically stipulate that these protections are provided **regardless of any contractual relationship which may be alleged to exist** between the contractor and such laborers and mechanics. Additionally, all laborers and mechanics must be paid unconditionally and not less often than once per week. HUD has followed DBA/DBRA prevailing wage parameters in its implementation, administration and enforcement of HUD-determined maintenance and nonroutine maintenance prevailing wage standards. (NOTE: The requirement to pay weekly wages is not applicable to the payment of prevailing routine maintenance wage rates related to laborers and mechanics engaged in the operation of PHA and IHA housing developments.)

¹ The DOL has issued an administrative policy which excludes "bona fide owner-operators of trucks who are independent contractors" from DBRA/CWHSSA provisions. See paragraph V.

PERSONNEL AND PARTICIPANT CONDITIONS

1. Non-Discrimination. In accordance with Section 109 of the Housing and Community Development Act of 1974, no person in the United States shall on the ground of race, color, religion, natural origin, or sex, be excluded from participation in, be denied the benefits of, or be subjected to discrimination under, any program or activity funded in whole or in part with CDBG funds. Bidder shall comply with 42 U.S.C. §5309, et. seq., 24 CFR §570.602 and 24 CFR Part 6. Bidder shall at all times comply with sections 104(b), 107 and 109 of the Housing and Community Development Act of 1974, as amended; Title VI of the Civil Rights Act of 1964 (42 U.S.C. §2000d, et seq.); and implementing regulations in 24 CFR Part 1. HUD's Title VI regulations specify types of prohibited discrimination. Bidder must not, for example, based on race, color, or national origin deny a person housing or services; provide different housing or services than those provided others; subject a person to segregation or separate treatment in the receipt of housing or services; use different admission or eligibility requirements for housing or services; or select a housing site or location with the purpose or effect of excluding or denying benefits to persons in protected classes.

Bidder shall also not discriminate on the basis of age under the Age Discrimination Act of 1975 (42 U.S.C. §6101, et. seq.) and the implementing regulations contained in 24 CFR Part 146, or on the basis of disability as provided in Section 504 of the Rehabilitation Act of 1973, and the implementing regulations contained in 24 CFR Part 8. Any contracts entered into by Lighthouse shall include a provision for compliance with these regulations. Bidder shall keep records and documentation demonstrating compliance with these regulations.

2. Equal Employment Opportunity. Bidder shall comply with 24 CFR §570.607, Executive Order 11246, as amended by Executive Orders 11375, 11478, 12086, and 12107 (Equal Employment Opportunity), and Executive Order 13279 (Equal Protection of the Laws for Faith Based Community Organizations) and the implementing regulations in 41 CFR Part 60, and the provisions of the Equal Employment Opportunity Clause. Any contracts entered into by Bidder shall include a provision for requiring compliance with these regulations and will, in all solicitations or advertisements for employees state that is an Equal Opportunity/Affirmative Action employer. Bidder shall keep records and documentation demonstrating compliance with these regulations.

3. Compliance with Davis-Bacon Act. Bidder shall comply with 24 CFR §570.603, and the requirements of the Secretary of Labor in accordance with the Davis-Bacon Act (40 U.S.C. §276(a) to (a-7)), as amended, and as supplemented by Department of Labor regulation 29 CFR Part 5. Any construction contracts entered into by Bidder shall include a provision for compliance with the Davis-Bacon Act and supporting Department of Labor regulations. Bidder shall also place a copy of the current prevailing wage determination issued by the Department of Labor in each solicitation and the award of the contract shall be conditioned upon the acceptance of the wage determination. If the attached Wage decision is no longer current at the time of contracting, Bidder must ensure that a current copy is used. Bidder shall ensure that a current copy of the Wage Decision and a copy of the Department of Labor poster called "Notice to All Employees" (Form WH-1521) shall be posted at the jobsite in a place that is easily accessible to all of the construction workers employed on the Project. Bidder shall also require the contractor to obtain weekly certified payroll reports. Bidder shall maintain documentation and records which demonstrate compliance with these regulations, including contract provisions and payroll records. Unless labor regulations require more frequent submission, such documentation shall be submitted to the City for review on a monthly basis.

4. Copeland "Anti-Kickback" Act. Bidder shall comply with the Copeland "Anti-Kickback" Act (18 U.S.C. §874) as supplemented by the Department of Labor regulations contained in 29 CFR Part 3. Any construction contracts entered into by Bidder shall include a provision for compliance with these regulations. Bidder shall maintain documentation and records which demonstrate compliance with these regulations. Such documentation shall be submitted to the City for review on a monthly basis.

The Wage Decision for your project will be provided.

5/1/2018

https://www.wdol.gov/wdol/scafiles/davisbacon/FL263.dvb?v=2

General Decision Number: FL180263 03/16/2018 FL263

Superseded General Decision Number: FL20170263

State: Florida

Construction Type: Building

County: Orange County in Florida.

BUILDING CONSTRUCTION PROJECTS (does not include single family homes or apartments up to and including 4 stories).

Note: Under Executive Order (EO) 13658, an hourly minimum wage of \$10.35 for calendar year 2018 applies to all contracts subject to the Davis-Bacon Act for which the contract is awarded (and any solicitation was issued) on or after January 1, 2015. If this contract is covered by the EO, the contractor must pay all workers in any classification listed on this wage determination at least \$10.35 per hour (or the applicable wage rate listed on this wage determination, if it is higher) for all hours spent performing on the contract in calendar year 2018. The EO minimum wage rate will be adjusted annually. Please note that this EO applies to the above-mentioned types of contracts entered into by the federal government that are subject to the Davis-Bacon Act itself, but it does not apply to contracts subject only to the Davis-Bacon Related Acts, including those set forth at 29 CFR 5.1(a)(2)-(60). Additional information on contractor requirements and worker protections under the EO is available at www.dol.gov/whd/govcontracts.

| Modification Number | Publication Date |
|---------------------|------------------|
| 0 | 01/05/2018 |
| 1 | 01/12/2018 |
| 2 | 03/16/2018 |

* ASBE0067-003 01/01/2018

| | Rates | Fringes |
|---|----------|---------|
| ASBESTOS WORKER/HEAT & FROST INSULATOR..... | \$ 27.89 | 15.19 |

CARP1905-003 06/01/2017

| | Rates | Fringes |
|-----------------------------------|----------|---------|
| CARPENTER (Includes Form Work)... | \$ 22.65 | 9.85 |

ELEV0139-002 01/01/2018

| | Rates | Fringes |
|------------------------|----------|---------|
| ELEVATOR MECHANIC..... | \$ 41.40 | 32.645 |

FOOTNOTE:

A. Employer contributions 8% of regular hourly rate to vacation pay credit for employee who has worked in business more than 5 years; Employer contributions 6% of regular hourly rate to vacation pay credit for employee who has worked in business less than 5 years.

Paid Holidays: New Year's Day; Memorial Day; Independence

Fencing Attachments

Omega Architectural

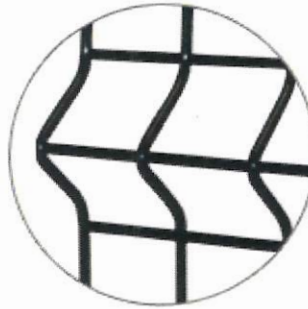
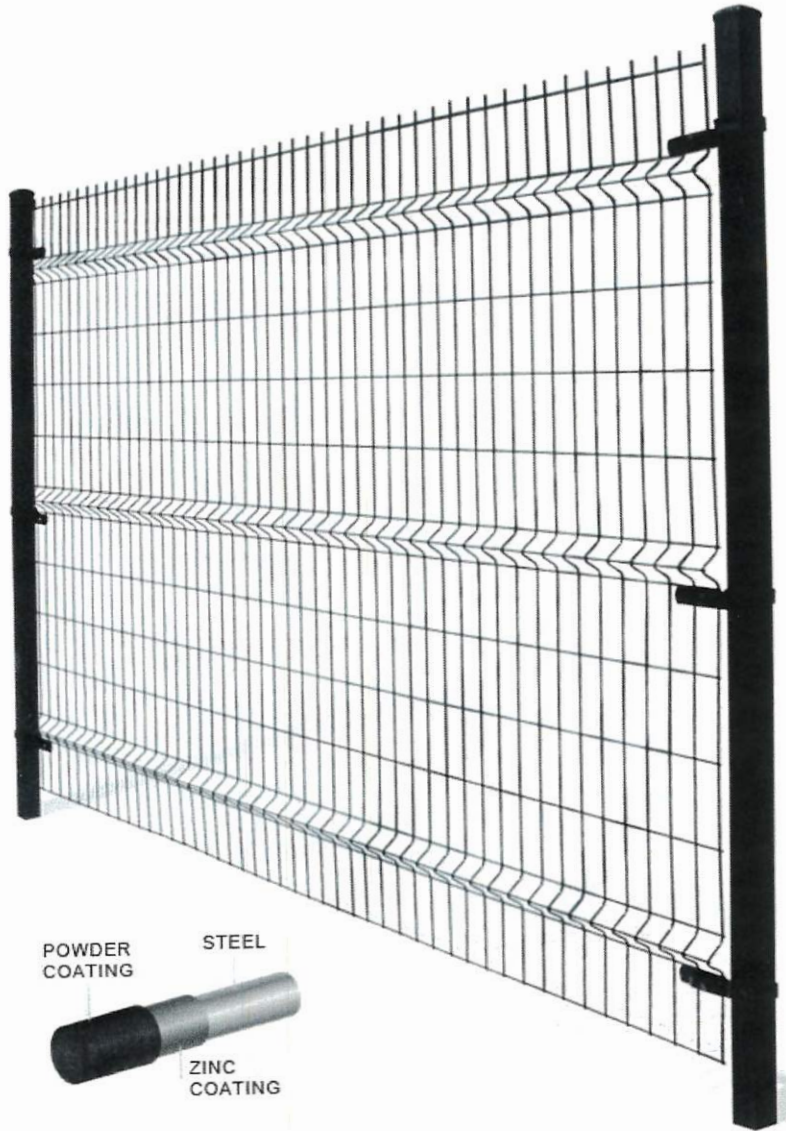

OMEGA ARCHITECTURAL

| | |
|-----------------------|--|
| Reinforcing bends | Gives strength to the fence |
| Horizontal wire | 6 GA |
| Vertical wire | 6 GA |
| Mesh opening | 2" x 6" - c/c nominal 1.77" x 5.80" – inside wires |
| Standard height | 4', 5', 6', 8' |
| Standard length | 7' 9" |
| Square post | 2"x2" or 3"x3" with Universal brackets (±1 1/2" slot allowance) |
| Caps | Two styles: square or square with ball |
| Special Panel Fitting | Versatile brackets adapt to many special applications |



1735 St-Elzear Blvd. West, Laval (Quebec) Canada H7L 3N6
 T 450 686-9600 | 1 800 836-6342 | F 450 681-7905
 www.omegatwo.com | customerservice@omegatwo.com



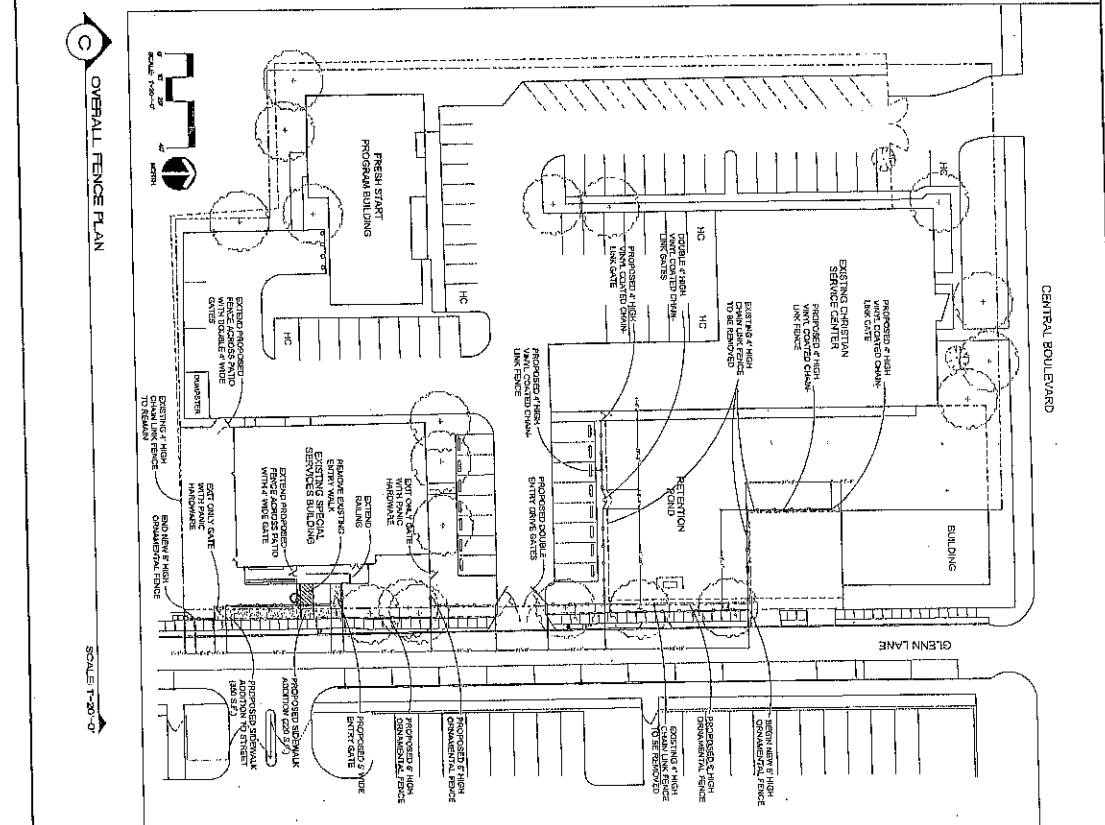
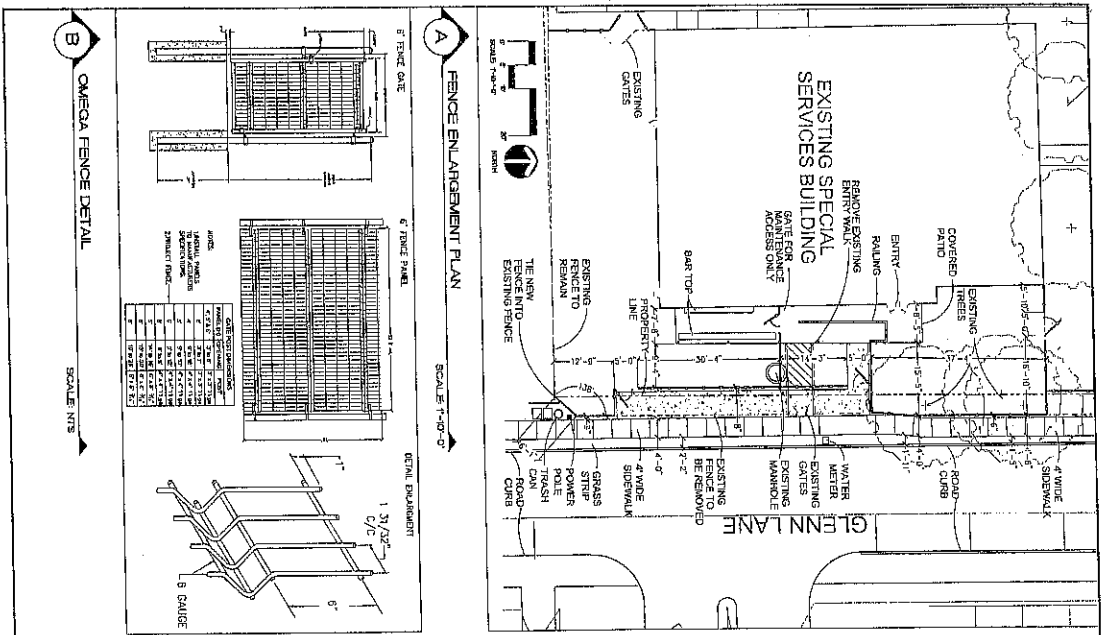

| NO. | DESCRIPTION | DATE | PROJECT ADDRESS | DRAWING TITLE | CROSS HATCH | SEAL |
|-----|-------------|----------|--|----------------------------|-------------|------|
| 1 | DESIGN | 08/11/11 | 1000 N. 10TH ST. SUITE 100 DENVER, CO 80202 | PROPOSED FENCE CONCEPT 'A' | | |
| 2 | CHECK | 08/11/11 | | | | |
| 3 | REVISION | 08/11/11 | | | | |
| 4 | SCALE | 08/11/11 | | | | |
| 5 | PROJECT NO. | 08/11/11 | | | | |
| 6 | CLIENT | 08/11/11 | | | | |
| 7 | DATE | 08/11/11 | | | | |

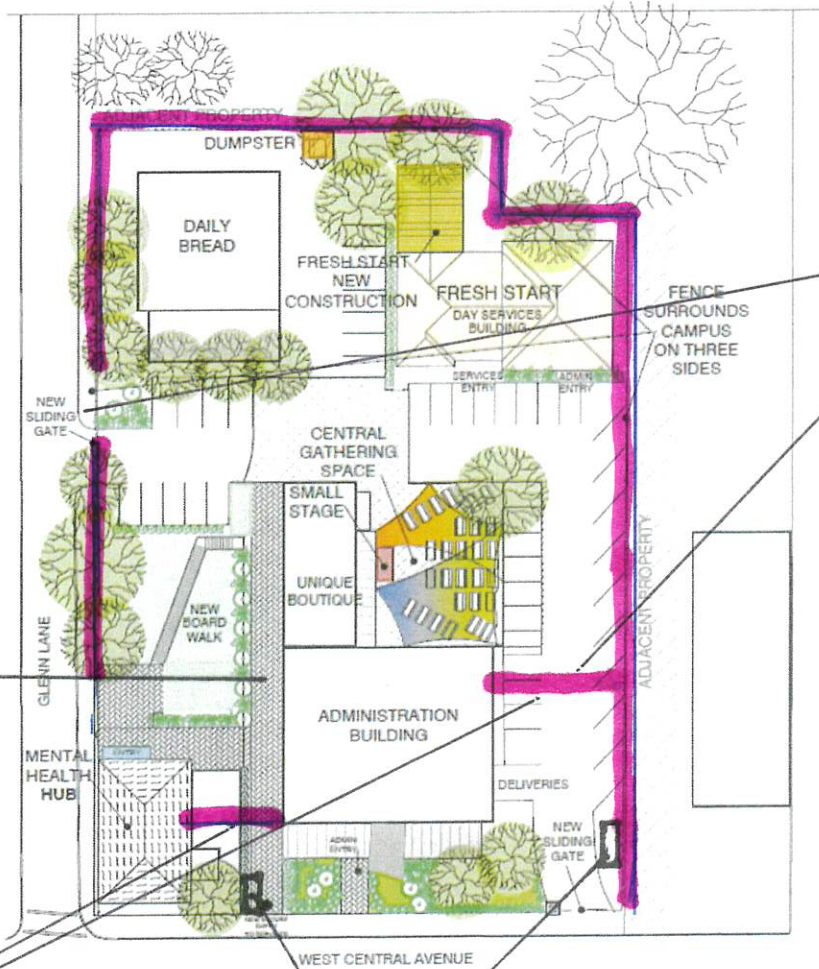

CHRISTIAN SERVICE CENTER
CAMPUS PLAN
2/24/2021

DRIVE Thru gates

 - New No Climb
6' Fencing

Pedestrian
PAVING & LIGHTING

4' walk thru
gates

Security Shelters / Pods / AC

Four 4' panic gates not indicated on this map, to be placed at recommendation of contractor

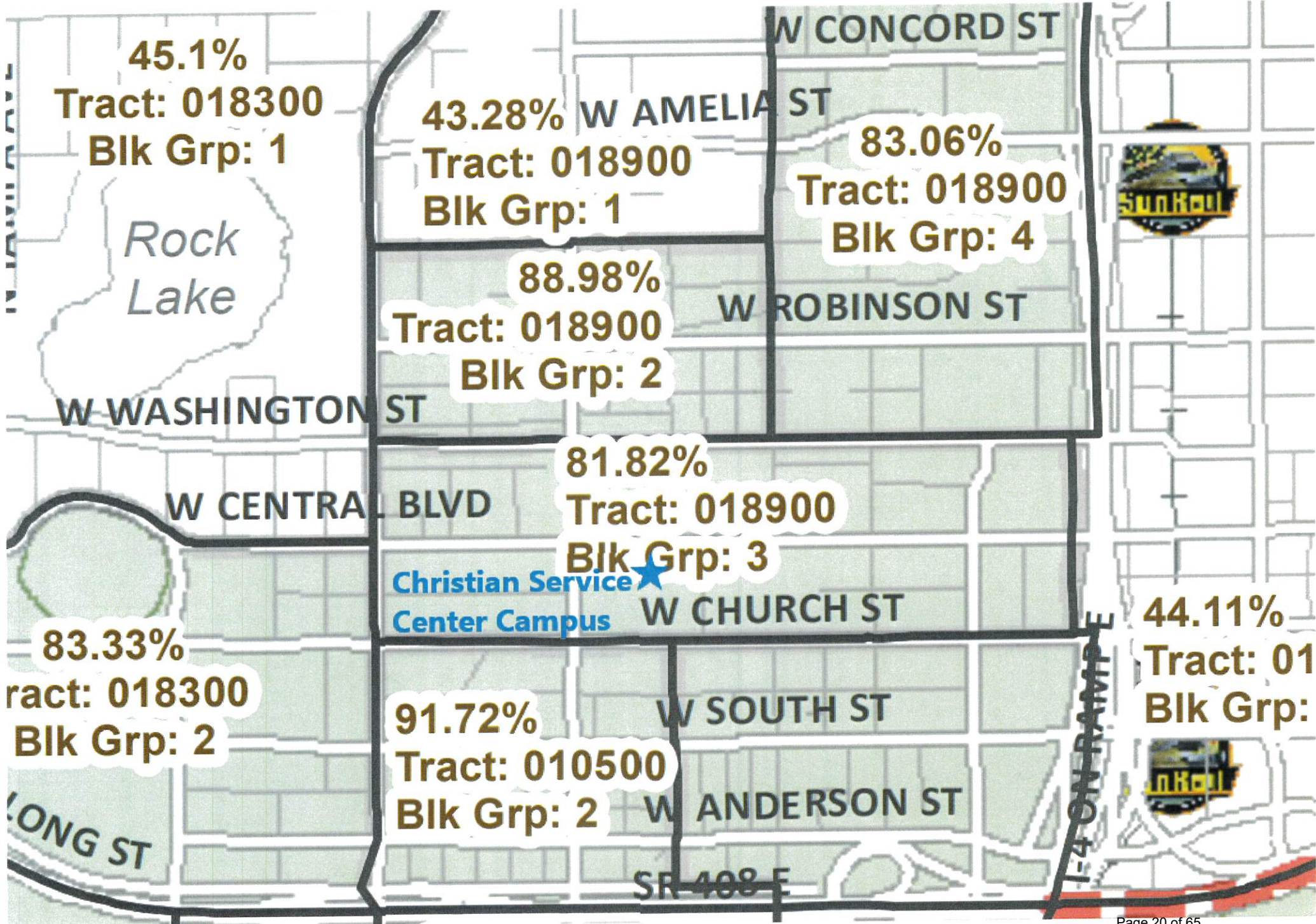

Security Kiosk Attachment 1 from
Twin Modular Services Incorporated New Jersey

GENERAL BUILDING SPECIFICATIONS:

Notice - guardboothonline.com, Inc claims proprietary rights in the information disclosed on this drawing. It is issued in confidence for engineering information only and may not be used, in whole or in part, to manufacture anything whether or not shown hereon, reproduced or disclosed to anyone without direct written permission from guardboothonline.com

- GENERAL:** Pre-assemble building fabricated from low maintenance, lightweight corrosive resistant aluminum (factory fabricated). Building exterior shall have no exposed fasteners.
- 1 DIMENSIONS:** 4'-0" wide x 6'-0" long and 94" nominal outside height. Interior dimension from floor to ceiling shall be 90".
 - 2 FRAME CONSTRUCTION:** Provide structural framing of 6063-T6 aluminum alloy extrusions. Members shall have a QUAKER BRONZE finish. Connections shall be fastened internally to framing system using mechanical fasteners or MIG welded where necessary. Exposed fasteners on framing system are not acceptable.
 - 3 BASE/FLOOR:** Floor structure shall be 1/8" aluminum anti-slip finished floor.
 - 4 LOWER WALL PANEL:** Exterior shall be .032 QUAKER BRONZE aluminum, 2 3/4" THERMAX insulation (R-18) and .032 interior aluminum. Overall thickness of panel shall be 3".
 - 5 CEILING/ROOF:** Constructed using Hardboard- Factory coated FRP with white finish exterior and interior. Roof drains into full perimeter gutter system.
 - 6 WINDOWS:** Fixed windows shall be single pane 1/4" clear tempered safety glass. Sliding window shall have aluminum frame (QUAKER BRONZE) and 1/4" clear tempered safety glass, insect screen, and locking device. Glass shall be glazed within wall system extrusions and not fastened to exterior wall. Glass sealed with concealed gasket system.
 - 7 DOOR:** Sliding door shall be extruded aluminum frame, half glass, top hung style using an overhead track and heavy duty ball bearing nylon tires with steel hub. Door shall be supplied with mortise hook bolt lockset with removable cylinder. Door color shall be QUAKER BRONZE.
 - 8 ELECTRICAL:** Building shall be wired according to N.E.C. standards. Load center shall be a 125 amp main lug, 120/240 unit with 8/16 open circuits. Wiring shall be within surface mounted EMT conduit, and included shall be (qty-1) GFI duplex receptacle with tester.
 - 9 LIGHTING:** Lighting shall be a dual bulb fluorescent light with pull switch.
 - 10 HEAT:** Heating shall be wall mounted electric with fan forced operation, 1500w/5120 BTU and thermostat in a enamel coated 20 ga, steel cabinet.
 - 11 COUNTER:** Full width x 24" deep x 3/4" thick white melamine work counter with (qty-1) cable grommet.

Bronze



White



CUSTOMER APPROVAL

- APPROVED
- APPROVED AS NOTED
- REVISE AND RESUBMIT

SIGNED: _____

DATE: _____

Twin Modular Services Inc.
 1001 Lower Landing Rd. ~Ste 607
 Blackwood, NJ. 08012



Twin Modular Services Inc.
 1001 Lower Landing Rd. Ste607
 Blackwood, NJ. 08012
 PHONE: 856-227-0057

e-mail:
 paul@twinmodular.com
 peter@twinmodular.com

WEBSITE:
 guardboothonline.com
 guardhousesonline.com
 guardshackonline.com

| | |
|--------------|------------------------------------|
| TITLE: | 4'-0" x 6'-0" Aluminum Building |
| JOB NO.: | |
| LOCATION: | Blackwood, NJ 08012 |
| MOD NO.: | 4 6GBALSD |
| COLOR: | QUAKER BRONZE |
| DATE: | 11/30/11 |
| DRAWN BY: | JWL |
| APPROVED BY: | |
| SCALE: | NONE |
| SHEET: | 1 |

Notice - guardboothonline.com claims proprietary rights in the information disclosed on this drawing. It is issued in confidence for engineering information only and may not be used, in whole or in part, to manufacture anything whether or not shown hereon, reproduced or disclosed to anyone without direct written permission from guardboothonline.com

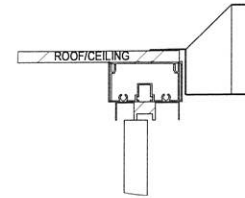
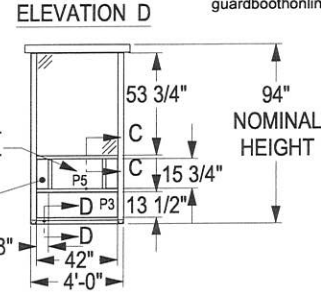
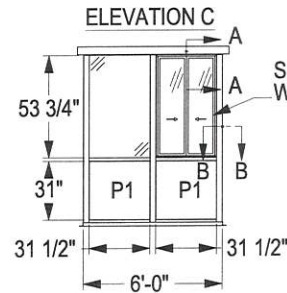
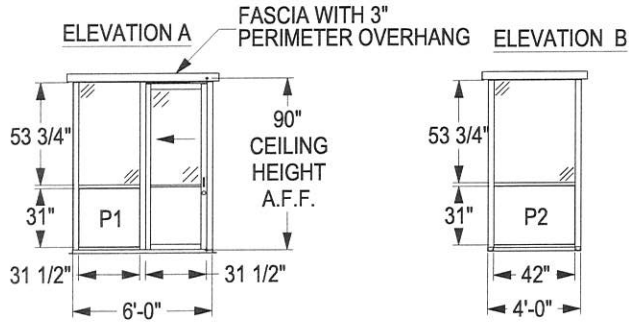

VIEW A-A
SCALE: 1 : 4

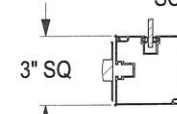

VIEW B-B
SCALE: 1 : 4

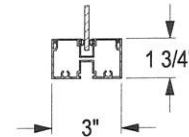

VIEW C-C
SCALE: 1 : 4

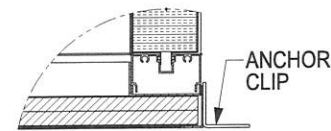

VIEW D-D
SCALE: 1 : 4

CERTIFICATION

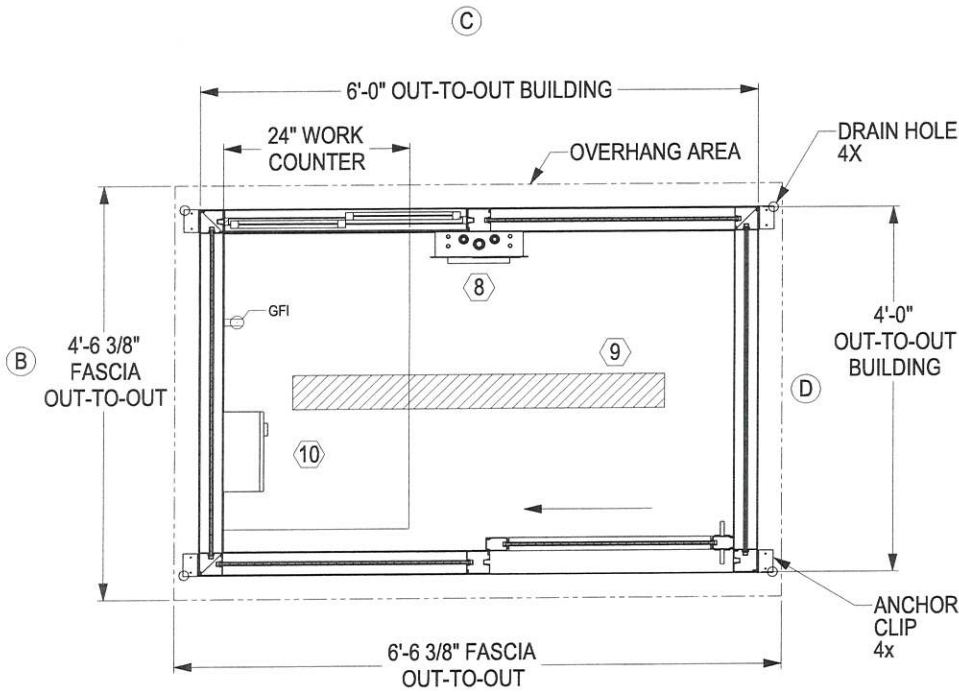

PLAN VIEW
SCALE: 1:12

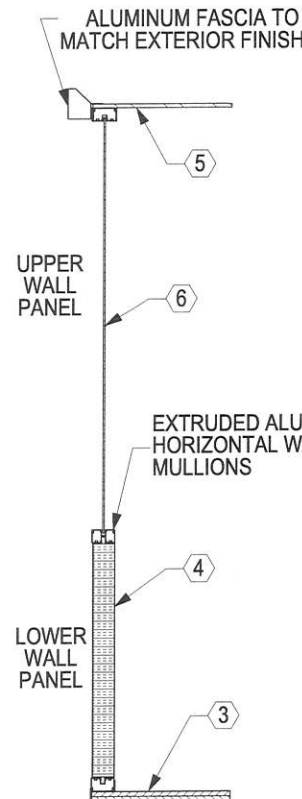

WALL SECTION DETAIL

1/4" CLEAR TEMPERED SAFETY GLASS

- 2@ 54 3/4" X 32 1/2"
- 2@ 54 3/4" X 43"
- 1@ 51" X 27" (SLIDE DOOR)
- 2@ 49 1/8" X 14 5/16" (SLIDE WINDOW)

CUSTOMER APPROVAL

- APPROVED
- APPROVED AS NOTED
- REVISE AND RESUBMIT

SIGNED: _____
DATE: _____

Twin Modular Services Inc.
1001 Lower Landing Rd. Ste 607
Blackwood, NJ, 08012



Twin Modular Services Inc. 1001 Lower Landing Rd. Ste607 Blackwood, NJ. 08012

PHONE: 856-227-0057
e-mail: paul@twinmodular.com peter@twinmodular.com

WEBSITE: guardboothonline.com guardhousesonline.com guardshackonline.com

TITLE: 4'-0" x 6'-0" Aluminum Building

JOB NO.:
LOCATION: Blackwood, NJ. 08012

MOD NO.: ALB46G30STK1DR

COLOR: QUAKER BRONZE

DATE: 11/30/11

DRAWN BY: JWJ

APPROVED BY:

SCALE: NONE

SHEET:
Page 23 of 65

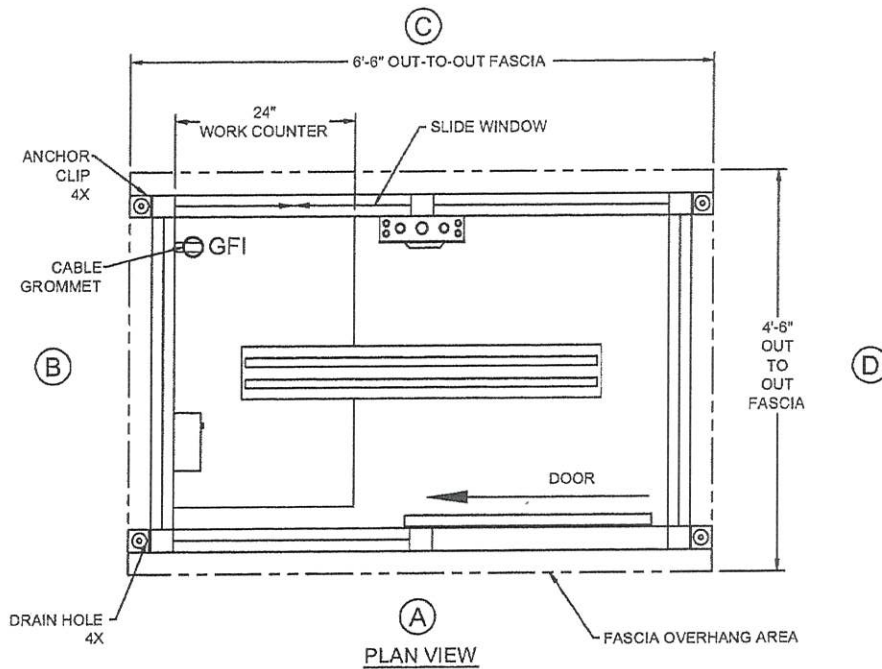
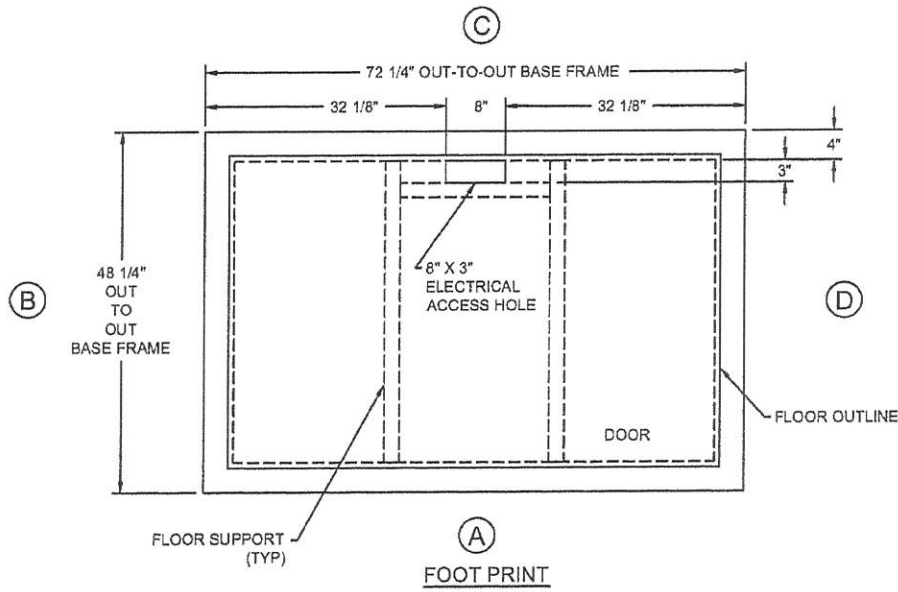

46GBALSD
(ELECTRICAL ACCESS HOLE)



Twin Modular Services Inc.
1001 Lower Landing Rd. Ste #607
Blackwood, NJ. 08012-3122
Phone: 856-227-0057
WEBSITE:
www.guardboothonline.com
E-mail: paul@twinmodular.com

Notice - Twin Modular Services Inc. claims proprietary rights in the information disclosed on this drawing. It is issued in confidence for engineering information only and may not be used, in whole or in part, to manufacture anything whether or not shown hereon, reproduced or disclosed to anyone without direct written permission from Twin Modular Services Inc.

| | |
|-----------|------------------------------------|
| TITLE | 4'-0" X 6'-0" ALUMINUM BUILDING |
| JOB NO: | 0180283 |
| QUOTE NO: | |
| LOCATION | |
| MOD NO: | 46GBALSD |
| COLOR: | SEE SPECIFICATIONS |
| DATE | 10.04.18 |
| DRAWN BY: | CDA |
| SCALE | 1/8" = 1' |
| SHEET | 1 OF 1 |

CERTIFICATION

Security Kiosk Attachment 2 from Panel Built Incorporated Georgia



Office: 800.636.3873

Fax: 800.594.3245

Email: sbrinkman@panelbuilt.com

Manufacturer of Structural Panelized Buildings, and Structural Steel Mezzanines

DATE: November 7, 2022

4' x 6' GUARD BOOTH

BASE AMOUNT OF PROPOSAL: \$ 7,800.00

- Shipping and Handling to FL: ADD \$ 2,000.00

CLARIFICATIONS & EXCLUSIONS:

- Permitting (If Required) By Others
- Foundations and/or Footers By Others
- Equipment Rental Provided By Customer
- Dumpster Rental / Disposal Provided by Customer

Shipment: Unit lead time 3-4 weeks.

CLASS A EXTERIOR WALLS- RATED FOR 90 MPH WIND LOADS (BINDER POST) STEEL BOTH SIDES OF WALL (S/S): 20 LF @ 8 FEET TALL

The walls shall be 3" thick composite sandwich panels. The outside and inside facings shall be 26 gage galvanized stucco embossed steel pre-painted white (other colors available upon request). The core shall be 2.865" of one pound density polystyrene laminated using a structural adhesive. Wall panels shall be insulated to a minimum of **R-11**. Every 4' will have an aluminum extruded binder post with snap cover to house all the electrical components. All binder posts, window trim and doors are painted to match the wall covering.

POLYSTYRENE CORE:

The polystyrene core shall have the following mechanical properties:

| | |
|---------------------------|---------------|
| Shear strength (flatwise) | 18 -22 PSI |
| Shear Modulus (flatwise) | 280 - 320 PSI |

The water absorption rate shall be less than 4%

STC Value: 32

ROOF

1/12 PITCH PANELIZED SHED ROOF W/ 9" OVERHANG: 29 SQUARE FEET

The roof shall be 3" thick composite sandwich panels. Both sides shall be stucco-embossed aluminum pre-painted white. The core shall be of 1 lb. density polystyrene foam. The entire panel shall be laminated together using a solvent free two-part polyurethane adhesive and pressure. The panels shall have formed edge connectors that are capable of being friction locked without mechanical fasteners using a full-length joint without through metal connectors. The joint shall allow lateral expansion and contraction.

DOORS

20 GAUGE INSULATED STEEL WITH 1/2 GLASS: 1 EACH

The door(s) shall be 36"w X 84"h X 1 3/4" thick and shall be constructed of 20 gauge hot dipped galvanized steel, mill treated for proper paint adherence. The door shall have top and bottom channel of 16 gauge steel projection welded to door skins on no less than 2" centers. The top channel is to be flush while the bottom channel is to be inverted. The hinge preparations are to be 9 gauge steel reinforcements projection welded to the door skins in six places each. Hinge preparation is to be cut through the doors and provided with reversible filler plates to allow building site handling. Standard hinge preparation is to be 4-1/2" regular weight .134" hinge, conforming to ANSI A1567, three preparations. The door frame shall be 16 gauge single "rabbet" commercial quality steel. The frame shall be pre-mortised for application of matching hinges and striker set of the door. The door shall be supplied with all necessary hardware as to meet local and state code requirements. The door shall be fabricated as to include **1/8" tempered safety glass** in the upper half. The window shall measure approximately 22"w X 36"h. Each door includes a sweep, threshold, satin chrome leverset and weather-stripping. All leversets are keyed alike.

WINDOWS

PICTURE WINDOW: 1 EACH

Picture windows shall be nominal 3'8" wide X 3' high (Other sizes used and available to fit certain building sizes). They shall be installed 42" off the floor. Window will be glazed with 1/4" **clear tempered glass** and shall be an integral part of the wall panel. The window shall be non-opening, and the entire window frame shall be painted in accordance with AAMA Specification 603.8.

HORIZONTAL SLIDING WINDOW: 2 EACH

Horizontal sliding windows shall be a nominal 3' wide x 3' high. They shall be installed 42" off the floor. Window will be glazed with 1/4" **insulated tempered glass**. The window shall be an integral part of the wall panel. One side shall be stationary; the other half shall slide. The window shall have an integral locking

mechanism with cam latch. The entire window frame shall be painted in accordance with AAMA Specification 603.8.

ELECTRICAL

(WIRED) ELECTRICAL PACKAGE:

The electrical package shall consist of a **(1)** wall switches; **(1)** duplex receptacles; **(1)** 110 volt 2x4 surface mounted LED fixtures (75 fc at desk height) with pre-wired electrical modules. Switches and receptacles are surface mounted in 2x4 handy boxes with modules consisting of MC cable with #12 AWG solid copper conductors. For switches and receptacles, the conductors tie into the apparatus in the usual fashion. Each module has a "power-in" tap, which plugs into a distribution or extender cable. As a circuit is filled, a "home run" is then made to the breaker box. Lighting is handled in a similar fashion, with the switch module acting as the "home run". Also, included shall be **(1)** 2x4 handy boxes for telephone/data connections no faceplate – wiring by others. NOTE: Tubes are not included, and final hookup of power to the breaker box must be made by a licensed electrician. This package meets NEC (current edition).

PBI WILL PRE-WIRE THE RECEPTACLES, LIGHTS, SWITCHES, & THROUGH-THE-WALL HVAC UNIT TO A PBI SUPPLIED LOAD CENTER ATTACHED TO THE BUILDING.

***IF THE HVAC IS ANYTHING OTHER THAN A THROUGH-THE-WALL UNIT, IT CANNOT BE PRE-WIRED (MODULAR WIRED).**

FINAL TIE-IN AND DATA/COMMUNICATIONS ARE BY OTHERS.

125 AMP SINGLE PHASE 120/240 Volt 8 SPACE MAIN LUG LOAD CENTER GE TLM812SCUD or equal 1 EACH

The electrical service shall include an indoor load center of sufficient amperage and circuit capacity as to handle all lighting loads, receptacles and Panel Built supplied HVAC systems. NOTE: The entire electrical system for the modular building shall be in accordance with the National Electrical Code and shall meet all N.E.C. requirements.

HVAC

AIR CONDITIONING - COOLING & HEATING: 1 EACH (TITLE 24)

The through-wall unit shall be **9,000** BTU's of cooling and **11,500** BTU's of heating. The unit shall be a through-the-wall type with panel preparation included. The unit shall be 230/208V, 60HZ, 20 AMP

FLOORING

2" TALL STEEL FORK LIFTABLE BASE: 1 EACH

Finished floor shall be **1/8" diamond plate** over a structural steel base. The base will include a 4" tube bolted at each corner for forklift access. These need to be removed prior to attaching base to existing concrete surface. Entire base shall be powder coated black.

MISCELLANEOUS ITEMS

18" DEEP STAINLESS STEEL COUNTER TOP: 1 @ 4 FEET

Counter tops shall be 18" deep with steel support legs every 6' or as shown on drawings. Each counter shall have a smooth front-facing edge and corners where countertops meet shall be mitered.

INSTALLATION: SEE OPTION

Installation to include only materials provided by Panel Built. Installation option assumes reasonable access to work area and typical working hours (8-5 M-F). Work area and lay down areas shall be broom cleaned daily as not to interfere with ongoing work in and around the warehouse facility. The onsite work area is to be free & clear of any existing obstructions, so that the crew can work quickly & efficiently. Panel Built will utilize either in-house installation crews or one of our regionally approved subcontractors to perform installations, as distance, timing, and other circumstances dictate. Forklift and/ or Heavy Equipment (if needed for the installation) and Unloading of material is not included. **EQUIPMENT MUST BE PROVIDED BY CUSTOMER**

(PLEASE ASK PANEL BUILT WHAT EQUIPMENT WILL BE NECESSARY). DUMPSTER RENTAL / DISPOSAL MUST BE PROVIDED BY CUSTOMER.

****IF THIS IS AN EXTERIOR BUILDING: IT IS NOTED IN OUR BUILDING WARRANTY THAT THE CONCRETE SLAB/ PAD SHOULD NOT EXTEND BEYOND THE BUILDING'S OUTER WALL DIMENSIONS. IF THE CONCRETE SLAB/ PAD EXTENDS BEYOND THE OUTER WALL DIMENSIONS, THIS CAUSES WATER TO POOL AT THE BASE OF THE WALL PANELS. THIS CAN VOID THE BUILDING WARRANTY.***

FREIGHT IS NOT INCLUDED: SEE OPTION

All the above, including all connectors, installation/shop drawings and bill of materials shall be shipped. Shipping method shall be determined by Panel Built and is dependent on the type, size, and weight of the material.

- **If shipment of materials is required to be via Flatbed, this will incur and additional cost equal to 1% of materials cost. (Ex: \$10K materials = \$100 Packaging Charge). DOES NOT APPLY TO MEZZANINES.**
- **Flex-Freight is available to our customers on the West Coast to help off-set long distance shipping costs. This means we will hold your shipment past the given lead time by up to 3 weeks in order to pair it with another shipment going in that direction.**

TERMS & CONDITIONS

In reading our proposal you will find that Panel-Built provides a complete package in that all the details are taken care of and nothing is left to the customer to "figure out." A few tasks that Panel-Built will perform for you are as follows:

- *Panel-Built's exclusive "RED LINE" policy. A full set of drawings are mailed to you for YOUR approval. We do not produce until you are happy with the layout.*
- *A full set of installation drawings for your files in case you later decide to take advantage of the unlimited flexibility of our modular wall systems.*
- *Our crews are fully insured and if needed Panel-Built can arrange for any bonding that the job may require.*
- *Panel-Built offers a full one year warrantee on the product and the workmanship, as well as extended warranties upon request.*

PANEL BUILT, INC. PAYMENT TERMS:

All sales are subject to final approval by finance department and may require alternate payment methods or terms. Each Order shall be considered a separate and independent transaction. Should Buyer default on payment of Order and Panel Built Inc. should employ an attorney to enforce any provision hereof or to collect damages for breach of Terms, Buyer agrees to pay Panel Built, Inc. its reasonable attorney fees and all other costs incurred by Panel Built, Inc. in connection with such suit and legal rate of interest and penalties as set forth below.

Standard Terms are as follows:

1. Sales under \$20,000 are standard net 30 days after shipment, or a 1% discount if paid within 10 days.
2. All pre-assembled structures require a 50% deposit and balance net 30 days after shipment.
3. Projects over \$20,000 will require partial payments determined by finance. If Panel Built is responsible for installation, terms are: 30% upon approval of drawings, 30% upon shipment, and 40% upon installation sign-off. If customer is responsible for installation, terms are: 30% upon approval of drawings, and 70% upon shipment.
4. Projects outside the continental USA will require down payment and payment in full prior to shipment.
5. Panel Built does not accept retainage on projects
6. If payment terms are not met, purchaser agrees to pay interest at the rate of 1% per month on the unpaid balance, and any legal or collection fees incurred by the seller.

Late Charges:

If you fail to pay the price or any other payment due to Panel Built, Inc. promptly when due, Panel Built, Inc. may require you to pay, in addition to the price or payment, interest thereon at a rate equal to the greater of 15% per annum or the maximum rate of interest allowable under applicable law from the original due date until full payment has been made by you or on your behalf.

This proposal is good for 30 days. For pricing beyond this period, we ask that you call our office.

Please note that price quoted does not include:

- *Any applicable Sales Tax*
- *Unloading and staging of materials at work site*
- *Equipment Rental (as needed for installation)*
- *Dumpster Rental / Disposal (if necessary)*
- *Permits, licenses or fees as required by governing agencies*
- *Relocation or modification of existing buildings or structures*
- *Running condensate lines and/or drains further than the edge of our structures*
- *Final connection to any utilities*
- *Site work, foundation work, and/or footers*
- *Compliance with appropriate building codes is the responsibility of the purchaser of the building*

Field installation for the modular building in this proposal is based upon the following assumptions:

- *This is a non-union installation and permits or licenses if required are the customer's responsibility.*
 - *Price does not include prevailing wage rates unless specifically noted.*
 - *Coordination with inspectors for the purpose of inspections and sign off are the customer's responsibility.*
 - *The available working hours are to be flexible, typically 7 AM to 6 PM and they are not restricted.*
 - *A typical workday is ten hours but may be extended at the option of our installation manager.*
 - *There will be no work stoppage or delays of the installation crew (e.g. waiting for other contractors to perform work, city inspections, etc.).*
 - *Weekend or holiday work time is available but is not part of the base price. However these hours can be worked at the discretion of the installation manager.*
 - *There are no restrictions of metal cutting, drilling, etc. in the area where the building is assembled.*
 - *Installation is only for products supplied by Panel-Built and specified in written quotation.*
 - *Electrical wiring, hookups to / into the service or breaker panel is not included.*
 - *Floor area where building will be installed is a flat, level concrete floor.*
 - *There is no finished floor installation unless specifically mentioned.*
 - *Area is clear and free of any obstructions such as columns, equipment, inventory, etc.*
 - *There are no field modifications or special cuts necessary other than quoted.*
 - *Some minor field modifications to the material may be required on site.*
 - *Unless specifically mentioned, equipment rental (i.e. forklift, scissor lift, etc. if necessary) is not included.*
- Installation is based upon use of customer supplied equipment.*
- *Unless specifically mentioned, dumpster rental / disposal is not included. Customer is to provide any necessary dumpster and disposal.*
 - *Unloading the product upon arrival (a forklift will be required) and staging at installation site is by the customer.*
 - *Written notification on all special instructions and prohibited procedures, materials, etc. shall be provided by the customer before the crew arrives.*
 - *Damage caused by customer will be charged price equal to quote plus additional freight or man hours involved to correct.*
 - *Change orders shall be in writing and may affect completion dates.*
 - *Unless specifically stated, quotation does not include customer required safety training classes or escorts around work area*

I accept the terms and conditions of this quotation:

Signed _____

Name _____ Title _____

Purchase Order No. _____

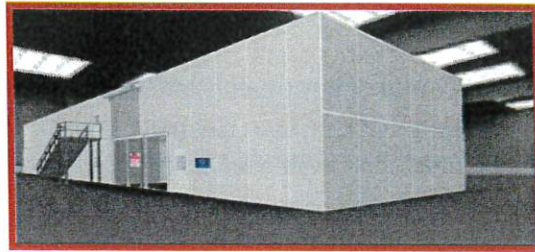

YOUR ACCEPTANCE OF ANY PRODUCTS SUPPLIED BY PANEL BUILT, INC. OR ON PANEL BUILT, INC. BEHALF, SHALL, WITHOUT LIMITATION, CONSTITUTE ACCEPTANCE OF ALL TERMS AND CONDITIONS STATED ABOVE.

PROJECT CRITERIA:

NAME OF DEVELOPMENT:

LOCATION OF DEVELOPMENT:

TOTAL INTERIOR FINISHED AREA IN SQUARE FEET:
21 SOFT

USE OF STRUCTURE:
PRE ASSEMBLED GUARD BOOTH

APPLICABLE CODES:

2019 CBC
2018 IBC

FLOOR DESIGN:

UNIFORM DEAD LOAD: 10 P.S.F.
UNIFORM LIVE LOAD: 50 P.S.F.
UNIFORM TOTAL LOAD: 60 P.S.F.

TOTAL LOAD DEFLECTION: L/240
LIVE LOAD DEFLECTION: L/960

ROOF DESIGN:

UNIFORM DEAD LOAD: 2 P.S.F.
UNIFORM LIVE LOAD: 20 P.S.F.
UNIFORM TOTAL LOAD: 22 P.S.F.

TOTAL LOAD DEFLECTION: L/240
LIVE LOAD DEFLECTION: L/360

WIND LOADING:

90 PSF

SNOW LOAD:

0 PSF

INSULATION RATING:

WALL PANELS: R-11
ROOF PANELS: R-11

SITE INSTALLED ITEMS:

BUILDING LOCATION, GEOMETRY, HEIGHT AND
PLACEMENT ARE DICTATED BY THE CUSTOMER AND
ARE NOT INCLUDED IN PANEL-BUILT SCOPE OF WORK.

FOUNDATION IS BY OTHERS AND SHALL BE
DESIGNED BY A LOCAL DESIGN PROFESSIONAL.

ACCESSIBILITY: RAMPS, STEPS, AND OTHER MEANS
OF INGRESS/EGRESS TO MEET ACCESSIBILITY
REQUIREMENTS AS ENFORCED BY THE LOCAL
AUTHORITY HAVING JURISDICTION IS BY OTHERS.

EXTERIOR BUILDING NOTES:

- OVERALL HEIGHT IS 9'-2" (NOMINAL).
- WALL PANELS ARE 3", 3-PLY, S/S AT 8'-0" HIGH
ROOF PANELS ARE 3", 3-PLY, A/A

S = 26 GA. STUCCO EMBOSSED STEEL
A = .030" STUCCO EMBOSSED ALUMINUM

3. APPLICATION : EXTERIOR BUILDING

4. COLORS: (PLEASE CHOOSE FROM THE FOLLOWING)

EXTERIOR AND INTERIOR WALLS: WHITE
ROOF PANELS INTERIOR AND EXTERIOR: WHITE (NO OPTIONS AVAILABLE)
DOORS: COLOR MATCHED TO WALLS
PICTURE WINDOWS: COLOR MATCHED TO WALLS
HORIZONTAL SLIDING WINDOWS: COLOR MATCHED TO WALLS
TRIM: COLOR MATCHED TO WALLS
STEEL BASE: BLACK (NO OPTIONS AVAILABLE)
1/8" STEEL DIAMOND PLATE FLOOR: BLACK (NO OPTIONS AVAILABLE)

5. STANDARD HEIGHTS:

DUPLEX RECEPTACLE HEIGHT IS 18" ABOVE FINISHED FLOOR TO CENTER
TELE/DATE PREP HEIGHT IS 18" ABOVE FINISHED FLOOR TO CENTER
SWITCH HEIGHT IS 48" ABOVE FINISHED FLOOR TO CENTER
WINDOW HEIGHT IS 42" ABOVE FINISHED FLOOR TO BOTTOM SILL

HVAC MOUNTING HEIGHT: 8" ABOVE FINISHED FLOOR

MANUFACTURER:

PANEL-BUILT
302 BEASLEY ST.
BLAIRSVILLE, GA 30512
PHONE: 800-636-3873
FAX: 706-745-1450

DEALER:

END USER:

SHEET #:

N-1
S-1
S-2
S-3
S-4
A-1
A-2
C-1
E-1

DRAWING TITLE:

COVER SHEET
FLOORPLAN
ELEVATIONS
STEEL BASE LAYOUTS
BUILDING LAYOUTS
BUILDING ATTACHMENTS
WINDOW ATTACHMENTS
COUNTERTOP LAYOUTS
CIRCUIT LAYOUT

| | |
|--|--|
| <p>LEGEND</p> <p>TELE/DATE PREP</p> <p>SWITCH</p> <p>DUPLEX RECEPTACLE</p> <p>WINDOW</p> <p>DOOR</p> <p>EXTENDED COLUMN</p> <p>COLUMN</p> <p>I BEAM (STRUCTURAL)</p> <p>COLD ROLLED MEMBER</p> <p>5-1/2"x1-1/2"x11 GA RAILING</p> <p>K-SERIES BAR JOIST</p> | |
| <p>JOB NUMBER:</p> <p>CONTRACTING</p> | <p>DRAWN BY: B. WILLIAMS</p> <p>CHECKED BY: R. DALTON</p> <p>DATE: 1.3.2022</p> <p>CONTRACTING</p> |
| <p>DEALER:</p> <p>THIS DRAWING IS THE PROPERTY OF PANEL-BUILT, INC. AND MAY NOT BE USED WITHOUT EXPRESS WRITTEN PERMISSION OF PANEL-BUILT, INC. ANY INFORMATION CONTAINED IN THIS DRAWING IS THE PROPERTY OF PANEL-BUILT, INC. AND MAY NOT BE USED IN WHOLE OR PART WITHOUT SPECIFIC WRITTEN PERMISSION OF PANEL-BUILT, INC.</p> | |
| <p>PANEL BUILT INCORPORATED</p> <p>302 BEASLEY STREET BLAIRSVILLE, GA 30512 CONTRACT US AT 800-636-3873 WWW.PANELBUILT.COM</p> | |
| <p>TOLERANCES: LENGTH ± 1/8", > 10'-0" ± 1/4" HOLES ± 1/16"</p> | |
| <p>PAGE: N-1</p> | |

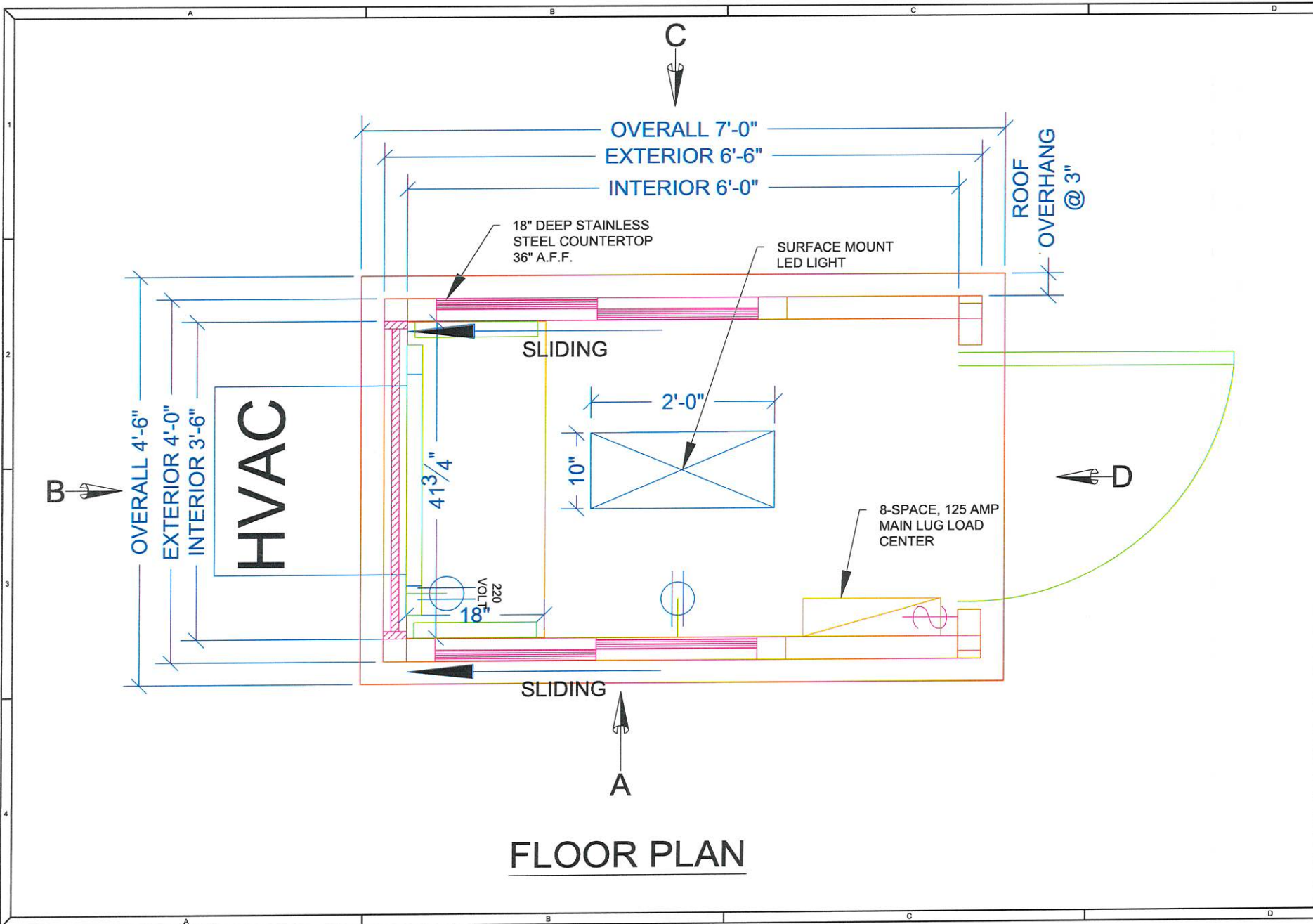

| LEGEND | |
|--------|-----------------------------|
| | TELEDATA PREP |
| | SWITCH |
| | DUPLEX RECEPTACLE |
| | WINDOW |
| | DOOR |
| | EXTENDED COLUMN |
| | COLUMN |
| | I BEAM (STRUCTURAL) |
| | COLD ROLLED MEMBER |
| | 1-1/2"x1-1/2"x11 GA RAILING |
| | K-SERIES BAR JOIST |

| | |
|-----------------------|-------------|
| JOB NUMBER | DEALER |
| DRAWN BY: B. WILLIAMS | CONTRACTING |
| CHECKED BY: R. DALTON | CONTRACTING |
| DATE: 1.3.2022 | |

THIS DRAWING IS THE PROPERTY OF PANEL-BUILT, INC. AND MAY NOT BE USED WITHOUT EXPRESS WRITTEN PERMISSION OF PANEL-BUILT, INC. INFORMATION SHOWN ON THIS DRAWING IS THE PROPERTY OF PANEL-BUILT, INC. AND MAY NOT BE USED IN WHOLE OR PART WITHOUT THE WRITTEN PERMISSION OF PANEL-BUILT, INC.

PANEL BUILT INCORPORATED
 302 BEASLEY STREET
 CONTACT US AT 800-245-3370 OR WWW.PANELBUILT.COM

TOLERANCES:
 LENGTH ± 1/8", > 10'-0" ± 1/4"
 HOLES ± 1/16"

PAGE: S-1

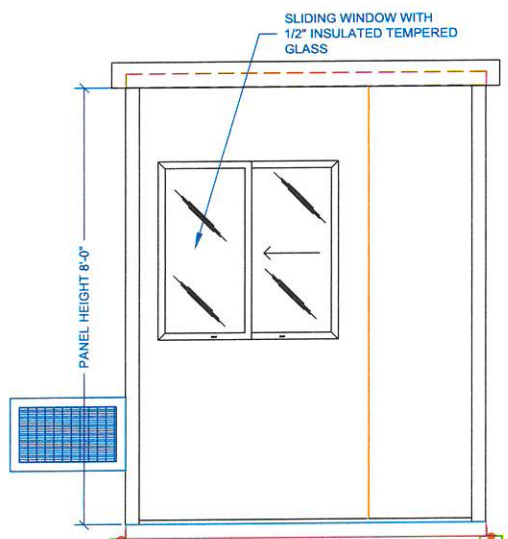

ELEVATION A

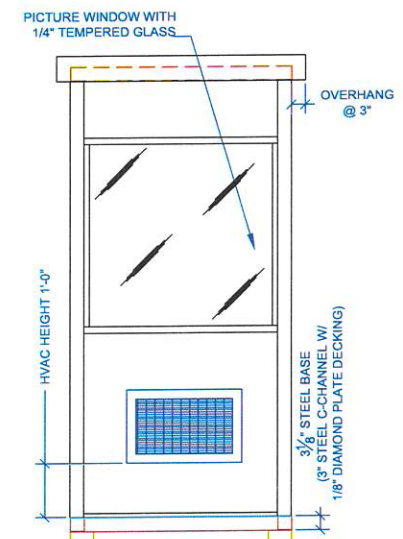

ELEVATION B

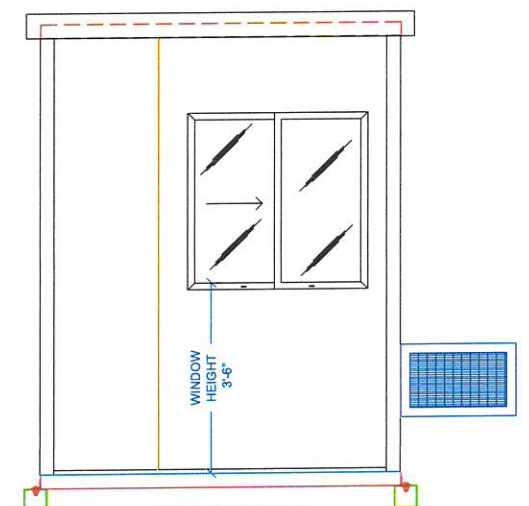

ELEVATION C

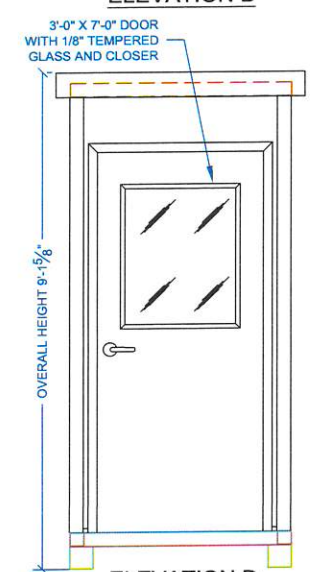

ELEVATION D

5"x5"x1/4" TUBE STEEL TO BE ATTACHED TO STEEL BASE AT 4 CORNERS TO ALLOW FOR FORKLIFT ACCESS. REMOVE PRIOR TO ANCHORING BUILDING

| LEGEND | |
|--------|-----------------------------|
| | TELEDATA PREP |
| | SWITCH |
| | DUPLEX RECEPTACLE |
| | WINDOW |
| | DOOR |
| | EXTENDED COLUMN |
| | COLUMN |
| | I BEAM (STRUCTURAL) |
| | COLD ROLLED MEMBER |
| | 1-1/2"x1-1/2"x11 GA RAILING |
| | K-SERIES BAR JOIST |

JOB NUMBER:
DRAWN BY: B. WILLIAMS
CHECKED BY: R. DALTON
DATE: 1.3.2022

DEALER:
CONTRACTING
CUSTOMER:
CONTRACTING

THIS DRAWING IS THE PROPERTY OF PANEL-BUILT, INC. AND MAY NOT BE USED WITHOUT EXPRESS WRITTEN PERMISSION OF PANEL-BUILT, INC. ALL INFORMATION CONTAINED HEREIN IS THE PROPERTY OF PANEL-BUILT, INC. AND MAY NOT BE USED IN WHOLE OR PART WITHOUT SPECIFIC WRITTEN PERMISSION OF PANEL-BUILT, INC.

PANEL BUILT INCORPORATED
302 BEASLEY STREET
CONTRACT, USA, TX 76033-5502
CONTACT: USA, TX 800.545.5002

TOLERANCES:
LENGTH ± 1/8", > 10'-0" ± 1/4"
HOLES ± 1/16"

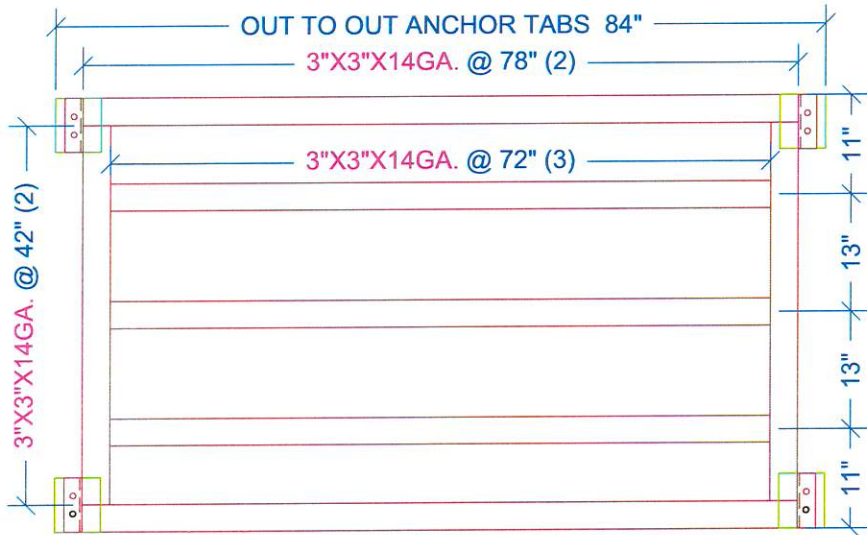

**4'-0"X6'-6" PRE-ASSEMBLED
STEEL BASE**

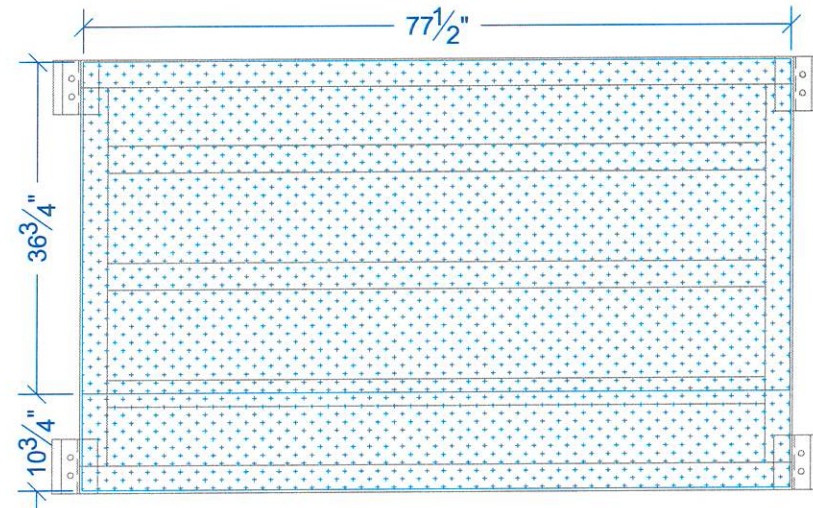

**1/8"TH STEEL DIAMOND
PLATE WELDED TO BASE**

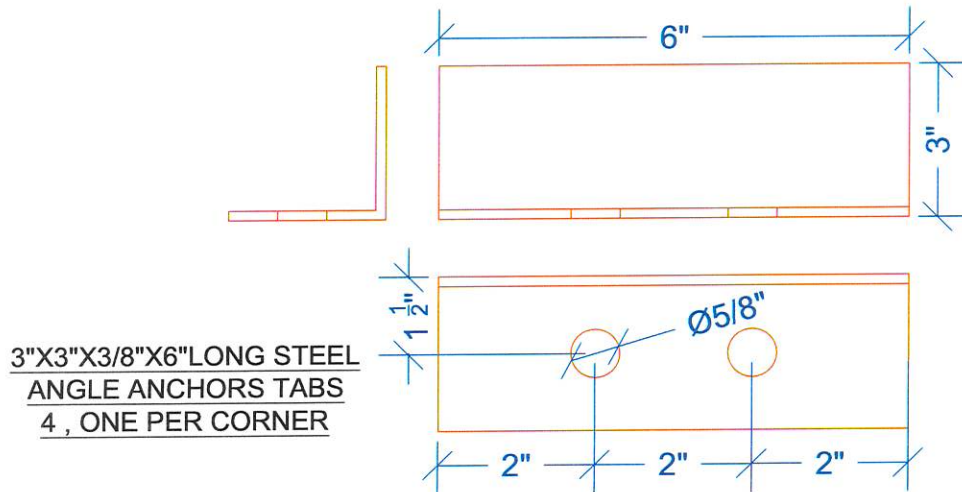

**3"X3"X3/8"X6" LONG STEEL
ANGLE ANCHORS TABS
4 , ONE PER CORNER**

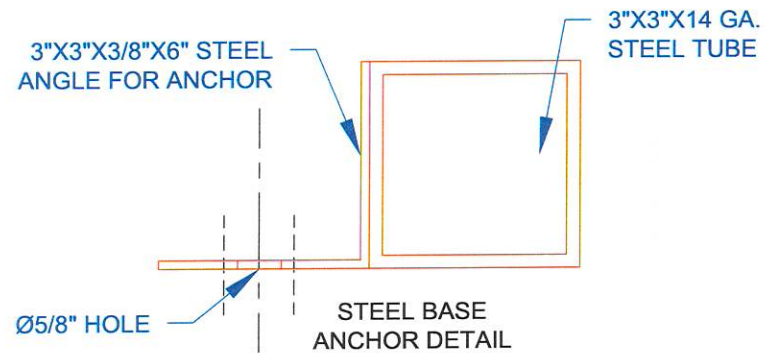

**STEEL BASE
ANCHOR DETAIL**

| LEGEND | |
|--------|-----------------------------|
| | TELEDATA PREP |
| | SWITCH |
| | DUPLEX RECEPTACLE |
| | WINDOW |
| | DOOR |
| | EXTENDED COLUMN |
| | COLUMN |
| | I BEAM (STRUCTURAL) |
| | COLD ROLLED MEMBER |
| | 1-1/2"X1-1/2"X11 GA RAILING |
| | K-SERIES BAR JOIST |

JOB NUMBER:
DRAWN BY: B. WILLIAMS
CHECKED BY: R. DALTON
DATE: 1.3.2022

DEALER: **CONTRACTING**
CUSTOMER: **CONTRACTING**

THIS DRAWING IS THE PROPERTY OF PANEL-BUILT, INC. AND MAY NOT BE USED WITHOUT EXPRESS WRITTEN PERMISSION OF PANEL-BUILT, INC. INFORMATION SHOWN ON THIS DRAWING IS THE PROPERTY OF PANEL-BUILT, INC. AND MAY NOT BE USED IN WHOLE OR PART WITHOUT THE WRITTEN PERMISSION OF PANEL-BUILT, INC.

**PANEL BUILT
INCORPORATED**
350 REALITY STREET
CONTACT US AT 800-536-5176 or www.panelbuilt.com

TOLERANCES:
LENGTH ± 1/8" > 10'-0" ± 1/4"
HOLES ± 1/16"

PAGE: S-3

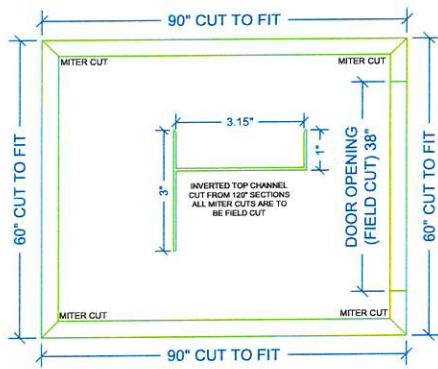

BASE CHANNEL LAYOUT

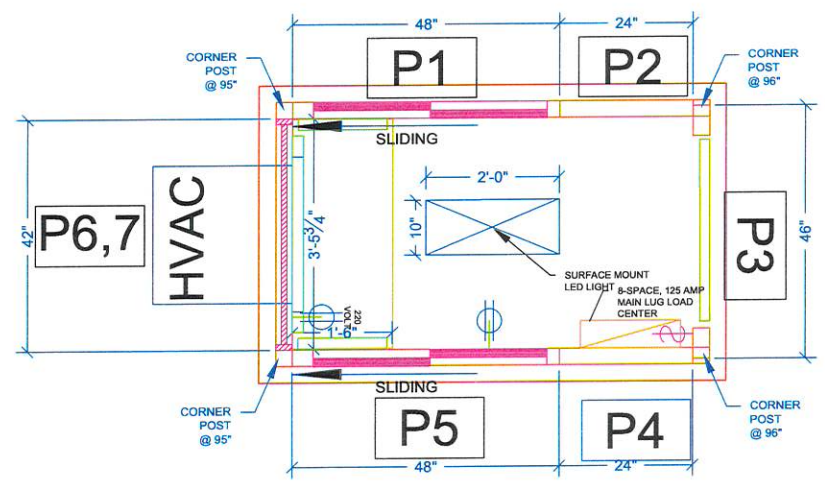

WALL PANEL LAYOUT

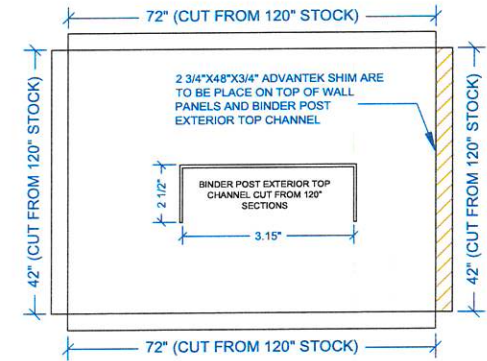

BASE CHANNEL LAYOUT

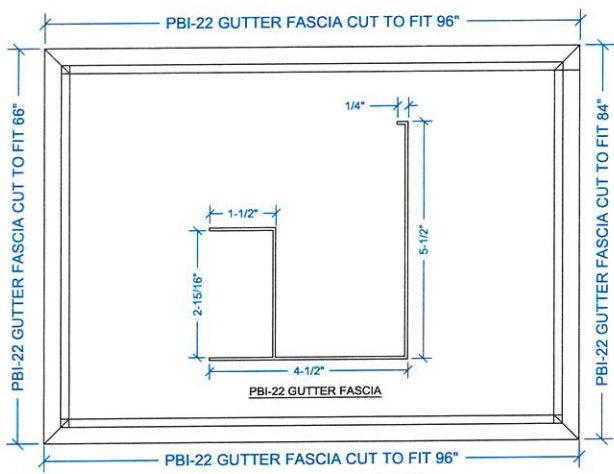

GUTTER LAYOUT

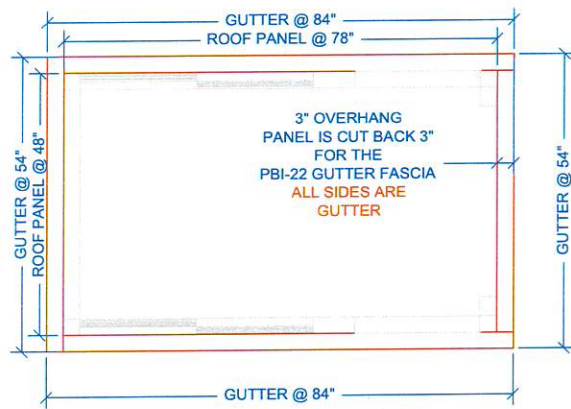

ROOF PANEL LAYOUT

LEGEND

| | |
|--|-----------------------------|
| | TELEDATA PREP |
| | SWITCH |
| | DUPLEX RECEPTACLE |
| | WINDOW |
| | DOOR |
| | EXTENDED COLUMN |
| | COLUMN |
| | I BEAM (STRUCTURAL) |
| | COLD ROLLED MEMBER |
| | 1-1/2"X1-1/2"X11 GA RAILING |
| | K-SERIES BAR JOIST |

JOB NUMBER:

DRAWN BY: B. WILLIAMS

CHECKED BY: R. DALTON

DATE: 1.3.2022

CONTRACTING

CONTRACTING

DEALER:

THIS DRAWING IS THE PROPERTY OF PANEL-BUILT, INC. AND MAY NOT BE USED WITHOUT EXPRESS WRITTEN PERMISSION OF PANEL-BUILT, INC. ALL INFORMATION CONTAINED IN THIS DRAWING IS THE PROPERTY OF PANEL-BUILT, INC. AND MAY NOT BE USED IN WHOLE OR PART WITHOUT SPECIFIC WRITTEN PERMISSION OF PANEL-BUILT, INC.

PANEL BUILT INCORPORATED

300 BEASLEY STREET
 W. ARDENVILLE, GA 30512
 CONTACT US AT 1-800-525-5252 panelbuilt.com

TOLERANCES:
 LENGTH ± 1/8", > 10'-0" ± 1/4"
 HOLES ± 1/16"

PAGE: S-3

BINDER POST EXTERIOR TOP CHANNEL ATTACHMENT

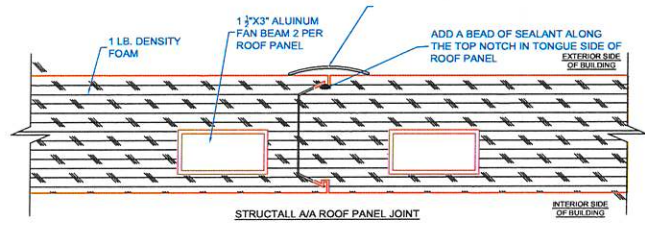
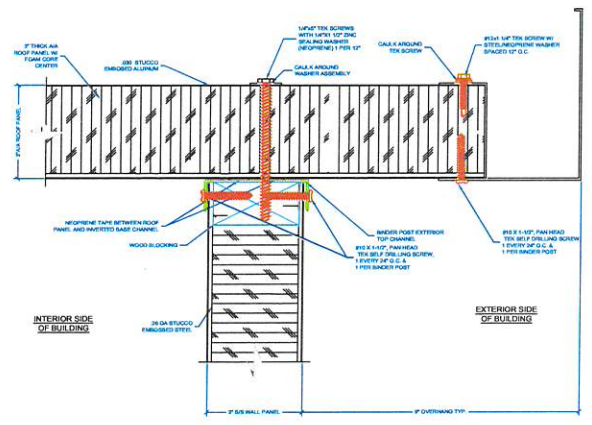
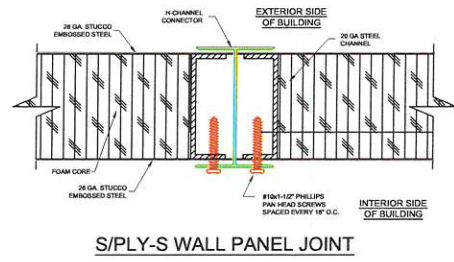
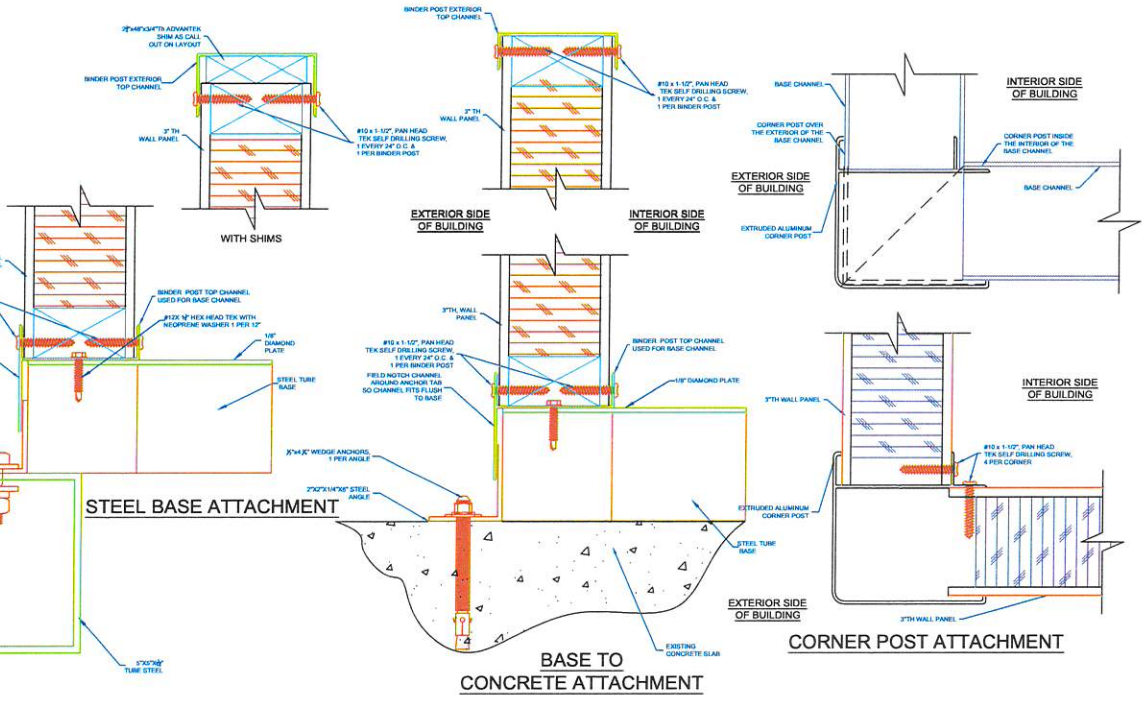

LEGEND

| | |
|--|---------------------------------|
| | TELEDATA PREP |
| | SWITCH |
| | DUPLEX RECEPTACLE |
| | WINDOW |
| | DOOR |
| | EXTENDED COLUMN |
| | COLUMN |
| | I BEAM (STRUCTURAL) |
| | COLD ROLLED MEMBER |
| | 1-1/2" x 1-1/2" x 11 GA RAILING |
| | K-SERIES BAR JOIST |

JOB NUMBER:
DRAWN BY: B. WILLIAMS
CHECKED BY: R. DALTON
DATE: 1.3.2022

CONTRACTING
CONTRACTING

DEALER:
CUSTOMER:

THIS DRAWING IS THE PROPERTY OF PANEL-BUILT, INC. AND IS NOT TO BE USED WITHOUT EXPRESS WRITTEN PERMISSION OF PANEL-BUILT, INC. ALL INFORMATION CONTAINED IN THIS DRAWING IS THE PROPERTY OF PANEL-BUILT, INC. AND MAY NOT BE USED IN WHOLE OR PART WITHOUT SPECIFIC WRITTEN PERMISSION OF PANEL-BUILT, INC.

PANEL BUILT INCORPORATED

300 BEASLEY STREET
CONTACT US AT 800.533.5333 OR WWW.PANELBUILT.COM

TOLERANCES:
LENGTH ± 1/8", > 10'-0" ± 1/4"
HOLES ± 1/16"

PAGE: A-1

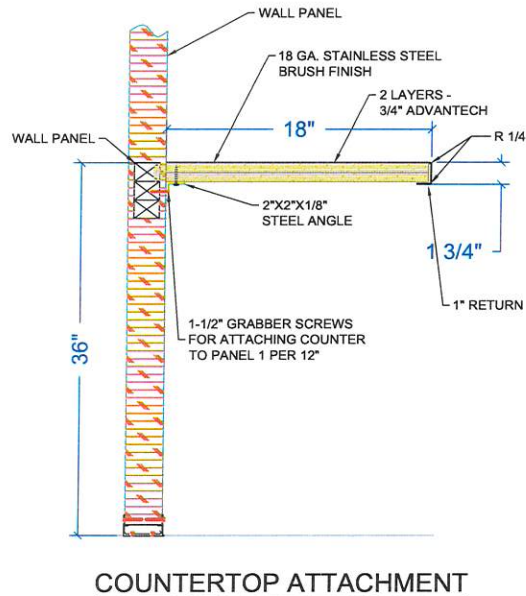
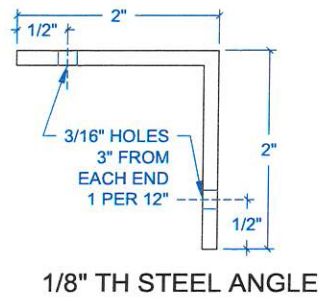
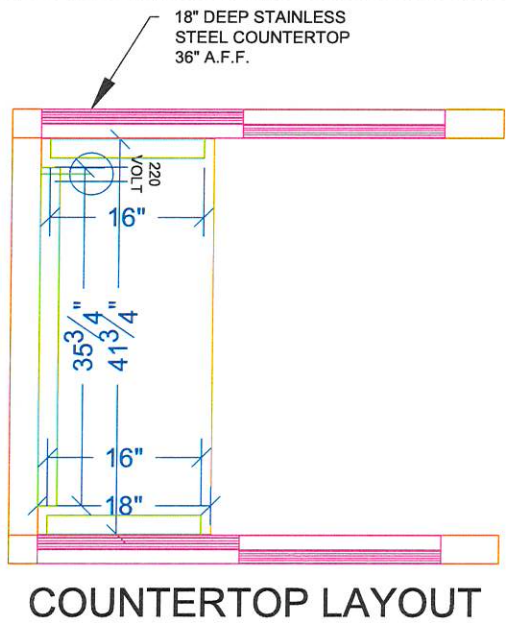

(2) SHEETS OF 3/4" T&G ADVANTEK AT ABOVE DIMENSIONS AND GLUE TO THE UNDER SIDE OF STAINLESS STEEL COUNTERTOP

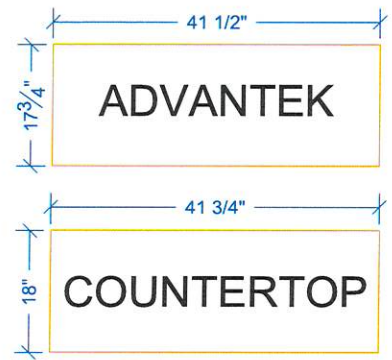

| LEGEND | |
|--------|---------------------------|
| | TELEDATA PREP |
| | SWITCH |
| | DUPLEX RECEPTACLE |
| | WINDOW |
| | DOOR |
| | EXTENDED COLUMN |
| | COLUMN |
| | I BEAM (STRUCTURAL) |
| | COLD ROLLED MEMBER |
| | 1-1/2X1-1/2X11 GA RAILING |
| | K-SERIES BAR JOIST |

| | |
|-----------------------|-------------|
| JOB NUMBER: | CONTRACTING |
| DRAWN BY: B. WILLIAMS | CONTRACTING |
| CHECKED BY: R. DALTON | |
| DATE: 1.3.2022 | |

DEALER: CONTRACTING

CUSTOMER: CONTRACTING

THIS DRAWING IS THE PROPERTY OF PANEL-BUILT, INC. AND IS NOT TO BE REPRODUCED OR USED WITHOUT THE WRITTEN PERMISSION OF PANEL-BUILT, INC. ALL INFORMATION SHOWN ON THIS DRAWING IS THE PROPERTY OF PANEL-BUILT, INC. AND MAY NOT BE USED IN WHOLE OR PART WITHOUT SPECIFIC WRITTEN PERMISSION OF PANEL-BUILT, INC.

PANEL BUILT INCORPORATED

302 BEASLEY STREET
MARIETTA, GA 30067
CONTACT US AT 770-592-2525 OR WWW.PANELBUILT.COM

TOLERANCES:
LENGTH ± 1/8" > 10'-0" ± 1/4"
HOLES ± 1/16"

PAGE: C-1

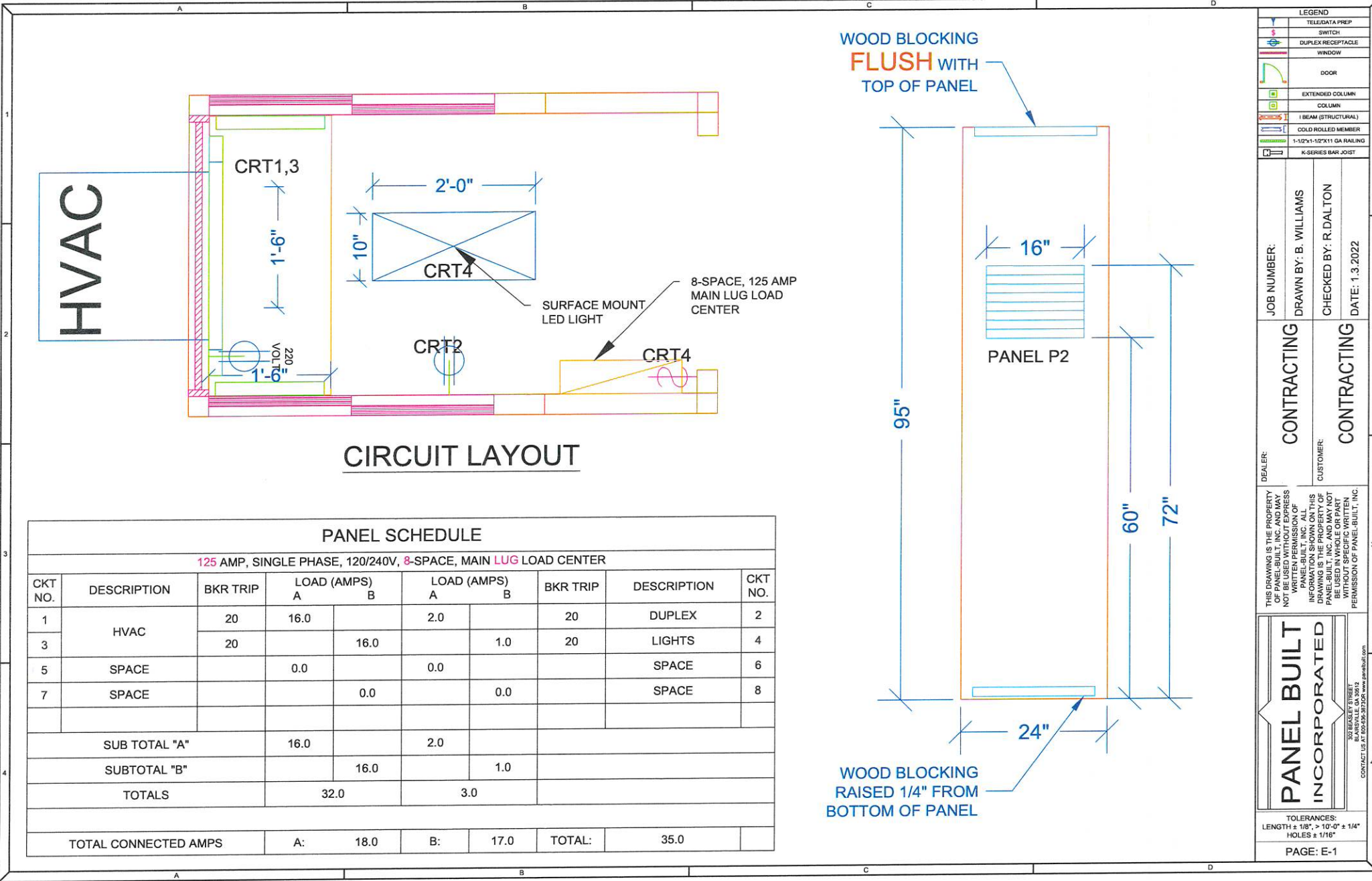

CIRCUIT LAYOUT

PANEL SCHEDULE

125 AMP, SINGLE PHASE, 120/240V, 8-SPACE, MAIN LUG LOAD CENTER

| CKT NO. | DESCRIPTION | BKR TRIP | LOAD (AMPS) | | LOAD (AMPS) | | BKR TRIP | DESCRIPTION | CKT NO. |
|----------------------|-------------|----------|-------------|------|-------------|------|----------|-------------|---------|
| | | | A | B | A | B | | | |
| 1 | HVAC | 20 | 16.0 | | 2.0 | | 20 | DUPLEX | 2 |
| 3 | | 20 | | 16.0 | | 1.0 | 20 | LIGHTS | 4 |
| 5 | SPACE | | 0.0 | | 0.0 | | | SPACE | 6 |
| 7 | SPACE | | | 0.0 | | 0.0 | | SPACE | 8 |
| SUB TOTAL "A" | | | 16.0 | | 2.0 | | | | |
| SUBTOTAL "B" | | | | 16.0 | | 1.0 | | | |
| TOTALS | | | | 32.0 | | 3.0 | | | |
| TOTAL CONNECTED AMPS | | | A: | 18.0 | B: | 17.0 | TOTAL: | 35.0 | |

LEGEND

| | |
|--|-----------------------------|
| | TELEDATA PREP |
| | SWITCH |
| | DUPLEX RECEPTACLE |
| | WINDOW |
| | DOOR |
| | EXTENDED COLUMN |
| | COLUMN |
| | I BEAM (STRUCTURAL) |
| | COLD ROLLED MEMBER |
| | 1-1/2"x1-1/2"x11 GA RAILING |
| | K-SERIES BAR JOIST |

JOB NUMBER:
DRAWN BY: B. WILLIAMS
CHECKED BY: R. DALTON
DATE: 1.3.2022

DEALER: CONTRACTING
CUSTOMER: CONTRACTING

THIS DRAWING IS THE PROPERTY OF PANEL-BUILT, INC. AND MAY BE REPRODUCED OR TRANSMITTED IN ANY FORM OR BY ANY MEANS WITHOUT WRITTEN PERMISSION OF PANEL-BUILT, INC. ALL INFORMATION SHOWN ON THIS DRAWING IS THE PROPERTY OF PANEL-BUILT, INC. AND IS NOT TO BE USED IN WHOLE OR PART WITHOUT SPECIFIC WRITTEN PERMISSION OF PANEL-BUILT, INC.

PANEL BUILT INCORPORATED
305 BURBANK STREET
BLANCKVILLE, GA 30512
CONTACT US AT 800-336-8722 OR WWW.PANELBUILT.COM

TOLERANCES:
LENGTH ± 1/8", > 10'-0" ± 1/4"
HOLES ± 1/16"
PAGE: E-1

Wage Determination

"General Decision Number: FL20230218 01/13/2023

Superseded General Decision Number: FL20220218

State: Florida

Construction Type: Building

County: Orange County in Florida.

BUILDING CONSTRUCTION PROJECTS (does not include single family homes or apartments up to and including 4 stories).

Note: Contracts subject to the Davis-Bacon Act are generally required to pay at least the applicable minimum wage rate required under Executive Order 14026 or Executive Order 13658. Please note that these Executive Orders apply to covered contracts entered into by the federal government that are subject to the Davis-Bacon Act itself, but do not apply to contracts subject only to the Davis-Bacon Related Acts, including those set forth at 29 CFR 5.1(a)(2)-(60).

| | |
|--|---|
| <p>If the contract is entered into on or after January 30, 2022, or the contract is renewed or extended (e.g., an option is exercised) on or after January 30, 2022:</p> | <ul style="list-style-type: none"> . Executive Order 14026 generally applies to the contract. . The contractor must pay all covered workers at least \$16.20 per hour (or the applicable wage rate listed on this wage determination, if it is higher) for all hours spent performing on the contract in 2023. |
| <p>If the contract was awarded on or between January 1, 2015 and January 29, 2022, and the contract is not renewed or extended on or after January 30, 2022:</p> | <ul style="list-style-type: none"> . Executive Order 13658 generally applies to the contract. . The contractor must pay all covered workers at least \$12.15 per hour (or the applicable wage rate listed on this wage determination, if it is higher) for all hours spent performing on that contract in 2023. |

The applicable Executive Order minimum wage rate will be adjusted annually. If this contract is covered by one of the Executive Orders and a classification considered necessary for performance of work on the contract does not appear on this wage determination, the contractor must still submit a conformance request.

Additional information on contractor requirements and worker protections under the Executive Orders is available at <http://www.dol.gov/whd/govcontracts>.

| Modification Number | Publication Date |
|---------------------|------------------|
| 0 | 01/06/2023 |
| 1 | 01/13/2023 |

ASBE0067-003 01/01/2021

| | Rates | Fringes |
|---|----------|---------|
| ASBESTOS WORKER/HEAT & FROST INSULATOR..... | \$ 30.12 | 13.11 |

CARP1905-003 06/01/2022

| | Rates | Fringes |
|-----------------------------------|----------|---------|
| CARPENTER (Includes Form Work)... | \$ 25.65 | 12.85 |

* ELEV0139-002 01/01/2023

| | Rates | Fringes |
|------------------------|----------|------------|
| ELEVATOR MECHANIC..... | \$ 49.28 | 37.335+a+b |

FOOTNOTE:

A. Employer contributions 8% of regular hourly rate to vacation pay credit for employee who has worked in business more than 5 years; Employer contributions 6% of regular hourly rate to vacation pay credit for employee who has worked in business less than 5 years.

Paid Holidays: New Year's Day; Memorial Day; Independence Day; Labor Day; Veterans Day; Thanksgiving Day; The Friday after Thanksgiving Day; and Christmas Day.

ENGI0487-022 07/01/2016

| | Rates | Fringes |
|-------------------------|----------|---------|
| OPERATOR: Forklift..... | \$ 23.25 | 9.20 |
| OPERATOR: Mechanic..... | \$ 32.05 | 9.20 |
| OPERATOR: Oiler..... | \$ 23.50 | 9.20 |

 ENGI0673-016 05/01/2021

| | Rates | Fringes |
|------------------------------|----------|---------|
| OPERATOR: Crane | | |
| Gantry Crane; Bridge Crane.. | \$ 30.57 | 14.60 |
| Tower Crane; Crawler | | |
| Crane; Truck Crane; Hydro | | |
| Crane..... | \$ 32.92 | 14.60 |

 IRON0402-001 10/01/2021

| | Rates | Fringes |
|-----------------------------|----------|---------|
| IRONWORKER, ORNAMENTAL..... | \$ 25.50 | 14.66 |

 * SFFL0821-004 01/01/2023

| | Rates | Fringes |
|------------------------|----------|---------|
| SPRINKLER FITTER (Fire | | |
| Sprinklers)..... | \$ 31.28 | 21.90 |

 SHEE0015-006 07/01/2022

| | Rates | Fringes |
|------------------------------|----------|---------|
| SHEET METAL WORKER (Includes | | |
| HVAC Duct Installation)..... | \$ 25.00 | 16.62 |

 * SUFL2014-027 08/16/2016

| | Rates | Fringes |
|-----------------------------------|----------|---------|
| CEMENT MASON/CONCRETE FINISHER... | \$ 19.39 | 0.00 |
| ELECTRICIAN, Includes Low | | |
| Voltage Wiring..... | \$ 19.58 | 6.39 |
| IRONWORKER, REINFORCING..... | \$ 22.81 | 11.58 |
| IRONWORKER, STRUCTURAL..... | \$ 17.92 | 0.00 |

| | | |
|--|-------------|------|
| LABORER: Common or General, Including Cement Mason Tending and Pipelaying..... | \$ 13.59 ** | 4.28 |
| OPERATOR: | | |
| Backhoe/Excavator/Trackhoe..... | \$ 18.69 | 3.27 |
| OPERATOR: Bulldozer..... | \$ 15.40 ** | 1.90 |
| OPERATOR: Grader/Blade..... | \$ 18.97 | 0.00 |
| OPERATOR: Loader..... | \$ 17.83 | 0.00 |
| OPERATOR: Roller..... | \$ 14.43 ** | 4.78 |
| PAINTER: Brush, Roller and Spray..... | \$ 13.22 ** | 0.00 |
| PIPEFITTER, Includes HVAC Pipe and Unit Installation..... | \$ 22.29 | 7.72 |
| PLUMBER..... | \$ 19.42 | 0.00 |
| ROOFER..... | \$ 17.60 | 1.39 |
| TILE SETTER..... | \$ 17.25 | 1.74 |
| TRUCK DRIVER: Dump Truck..... | \$ 12.95 ** | 2.28 |
| TRUCK DRIVER: Lowboy Truck..... | \$ 14.24 ** | 0.00 |

WELDERS - Receive rate prescribed for craft performing operation to which welding is incidental.

=====
 ** Workers in this classification may be entitled to a higher minimum wage under Executive Order 14026 (\$16.20) or 13658 (\$12.15). Please see the Note at the top of the wage determination for more information.

Note: Executive Order (EO) 13706, Establishing Paid Sick Leave for Federal Contractors applies to all contracts subject to the Davis-Bacon Act for which the contract is awarded (and any solicitation was issued) on or after January 1, 2017. If this contract is covered by the EO, the contractor must provide employees with 1 hour of paid sick leave for every 30 hours

they work, up to 56 hours of paid sick leave each year. Employees must be permitted to use paid sick leave for their own illness, injury or other health-related needs, including preventive care; to assist a family member (or person who is like family to the employee) who is ill, injured, or has other health-related needs, including preventive care; or for reasons resulting from, or to assist a family member (or person who is like family to the employee) who is a victim of, domestic violence, sexual assault, or stalking. Additional information on contractor requirements and worker protections under the EO is available at <https://www.dol.gov/agencies/whd/government-contracts>.

Unlisted classifications needed for work not included within the scope of the classifications listed may be added after award only as provided in the labor standards contract clauses (29CFR 5.5 (a) (1) (ii)).

The body of each wage determination lists the classification and wage rates that have been found to be prevailing for the cited type(s) of construction in the area covered by the wage determination. The classifications are listed in alphabetical order of "identifiers" that indicate whether the particular rate is a union rate (current union negotiated rate for local), a survey rate (weighted average rate) or a union average rate (weighted union average rate).

Union Rate Identifiers

A four letter classification abbreviation identifier enclosed in dotted lines beginning with characters other than "SU" or "UAVG" denotes that the union classification and rate were prevailing for that classification in the survey. Example: PLUM0198-005 07/01/2014. PLUM is an abbreviation identifier of the union which prevailed in the survey for this classification, which in this example would be Plumbers. 0198 indicates the local union number or district council number where applicable, i.e., Plumbers Local 0198. The next number, 005 in the example, is an internal number used in processing the wage determination. 07/01/2014 is the effective date of the most current negotiated rate, which in this example is July 1, 2014.

Union prevailing wage rates are updated to reflect all rate changes in the collective bargaining agreement (CBA) governing

this classification and rate.

Survey Rate Identifiers

Classifications listed under the ""SU"" identifier indicate that no one rate prevailed for this classification in the survey and the published rate is derived by computing a weighted average rate based on all the rates reported in the survey for that classification. As this weighted average rate includes all rates reported in the survey, it may include both union and non-union rates. Example: SULA2012-007 5/13/2014. SU indicates the rates are survey rates based on a weighted average calculation of rates and are not majority rates. LA indicates the State of Louisiana. 2012 is the year of survey on which these classifications and rates are based. The next number, 007 in the example, is an internal number used in producing the wage determination. 5/13/2014 indicates the survey completion date for the classifications and rates under that identifier.

Survey wage rates are not updated and remain in effect until a new survey is conducted.

Union Average Rate Identifiers

Classification(s) listed under the UAVG identifier indicate that no single majority rate prevailed for those classifications; however, 100% of the data reported for the classifications was union data. EXAMPLE: UAVG-OH-0010 08/29/2014. UAVG indicates that the rate is a weighted union average rate. OH indicates the state. The next number, 0010 in the example, is an internal number used in producing the wage determination. 08/29/2014 indicates the survey completion date for the classifications and rates under that identifier.

A UAVG rate will be updated once a year, usually in January of each year, to reflect a weighted average of the current negotiated/CBA rate of the union locals from which the rate is based.

WAGE DETERMINATION APPEALS PROCESS

1.) Has there been an initial decision in the matter? This can be:

- * an existing published wage determination

- * a survey underlying a wage determination
- * a Wage and Hour Division letter setting forth a position on a wage determination matter
- * a conformance (additional classification and rate) ruling

On survey related matters, initial contact, including requests for summaries of surveys, should be with the Wage and Hour National Office because National Office has responsibility for the Davis-Bacon survey program. If the response from this initial contact is not satisfactory, then the process described in 2.) and 3.) should be followed.

With regard to any other matter not yet ripe for the formal process described here, initial contact should be with the Branch of Construction Wage Determinations. Write to:

Branch of Construction Wage Determinations
 Wage and Hour Division
 U.S. Department of Labor
 200 Constitution Avenue, N.W.
 Washington, DC 20210

2.) If the answer to the question in 1.) is yes, then an interested party (those affected by the action) can request review and reconsideration from the Wage and Hour Administrator (See 29 CFR Part 1.8 and 29 CFR Part 7). Write to:

Wage and Hour Administrator
 U.S. Department of Labor
 200 Constitution Avenue, N.W.
 Washington, DC 20210

The request should be accompanied by a full statement of the interested party's position and by any information (wage payment data, project description, area practice material, etc.) that the requestor considers relevant to the issue.

3.) If the decision of the Administrator is not favorable, an interested party may appeal directly to the Administrative Review Board (formerly the Wage Appeals Board). Write to:

Administrative Review Board
 U.S. Department of Labor
 200 Constitution Avenue, N.W.
 Washington, DC 20210

4.) All decisions by the Administrative Review Board are final.

=====

END OF GENERAL DECISIO"

Federal Labor Standards Provisions

Federal Labor Standards Provisions U.S. Department of Housing and Urban Development

Office of Labor Relations Previous editions are obsolete Page 1 of 5 form HUD-4010 (06/2009) ref. Handbook 1344.1

Applicability

The Project or Program to which the construction work covered by this contract pertains is being assisted by the United States of America and the following Federal Labor Standards Provisions are included in this Contract pursuant to the provisions applicable to such Federal assistance.

A. 1. (i) Minimum Wages. All laborers and mechanics employed or working upon the site of the work, will be paid unconditionally and not less often than once a week, and without subsequent deduction or rebate on any account (except such payroll deductions as are permitted by regulations issued by the Secretary of Labor under the Copeland Act (29 CFR Part 3), the full amount of wages and bona fide fringe benefits (or cash equivalents thereof) due at time of payment computed at rates not less than those contained in the wage determination of the Secretary of Labor which is attached hereto and made a part hereof, regardless of any contractual relationship which may be alleged to exist between the contractor and such laborers and mechanics. Contributions made or costs reasonably anticipated for bona fide fringe benefits under Section I(b)(2) of the Davis-Bacon Act on behalf of laborers or mechanics are considered wages paid to such laborers or mechanics, subject to the provisions of 29 CFR 5.5(a)(1)(iv); also, regular contributions made or costs incurred for more than a weekly period (but not less often than quarterly) under plans, funds, or programs, which cover the particular weekly period, are deemed to be constructively made or incurred during such weekly period. Such laborers and mechanics shall be paid the appropriate wage rate and fringe benefits on the wage determination for the classification of work actually performed, without regard to skill, except as provided in 29 CFR 5.5(a)(4). Laborers or mechanics performing work in more than one classification may be compensated at the rate specified for each classification for the time actually worked therein: Provided, That the employer's payroll records accurately set forth the time spent in each classification in which work is performed. The wage determination (including any additional classification and wage rates conformed under 29 CFR 5.5(a)(1)(ii) and the Davis-Bacon poster (WH-1321) shall be posted at all times by the contractor and its subcontractors at the site of the work in a prominent and accessible, place where it can be easily seen by the workers.

(ii) (a) Any class of laborers or mechanics which is not listed in the wage determination and which is to be employed under the contract shall be classified in conformance with the wage determination. HUD shall approve an additional classification and wage rate and fringe benefits therefor only when the following criteria have been met: **(1)** The work to be performed by the classification requested is not performed by a classification in the wage determination; and

(2) The classification is utilized in the area by the construction industry; and

(3) The proposed wage rate, including any bona fide fringe benefits, bears a reasonable relationship to the wage rates contained in the wage determination.

(b) If the contractor and the laborers and mechanics to be employed in the classification (if known), or their representatives, and HUD or its designee agree on the classification and wage rate (including the amount designated for fringe benefits where appropriate), a report of the action taken shall be sent by HUD or its designee to the Administrator of the Wage and Hour Division, Employment Standards Administration, U.S. Department of Labor, Washington, D.C. 20210. The Administrator, or an authorized representative, will approve, modify, or disapprove every additional classification action within 30 days of receipt and so advise HUD or its designee or will notify HUD or its designee within the 30-day period that additional time is necessary. (Approved by the Office of Management and Budget under OMB control number 1215-0140.)

(c) In the event the contractor, the laborers or mechanics to be employed in the classification or their representatives, and HUD or its designee do not agree on the proposed classification and wage rate (including the amount designated for fringe benefits, where appropriate), HUD or its designee shall refer the questions, including the views of all interested parties and the recommendation of HUD or its designee, to the Administrator for determination. The Administrator, or an authorized representative, will issue a determination within 30 days of receipt and so advise HUD or its designee or will notify HUD or its designee within the 30-day period that additional time is necessary. (Approved by the Office of Management and Budget under OMB Control Number 1215-0140.)

(d) The wage rate (including fringe benefits where appropriate) determined pursuant to subparagraphs (1)(ii)(b) or (c) of this paragraph, shall be paid to all workers performing work in the classification under this contract from the first day on which work is performed in the classification.

(iii) Whenever the minimum wage rate prescribed in the contract for a class of laborers or mechanics includes a fringe benefit which is not expressed as an hourly rate, the contractor shall either pay the benefit as stated in the wage determination or shall pay another bona fide fringe benefit or an hourly cash equivalent thereof.

(iv) If the contractor does not make payments to a trustee or other third person, the contractor may consider as part Previous editions are obsolete Page 2 of 5 form **HUD-4010** (06/2009) ref. Handbook 1344.1 of the wages of any laborer or mechanic the amount of any costs reasonably anticipated in providing bona fide fringe benefits under a plan or program, Provided, That the Secretary of Labor has found, upon the written request of the contractor, that the applicable standards of the Davis-Bacon Act have been met. The Secretary of Labor may require the contractor to set aside in a separate account assets for the meeting of obligations under the plan or program. (Approved by the Office of Management and Budget under OMB Control Number 1215-0140.)

2. Withholding. HUD or its designee shall upon its own action or upon written request of an authorized representative of the Department of Labor withhold or cause to be withheld from the contractor under this contract or any other Federal contract with the same prime contractor, or any other Federally-assisted contract subject to Davis-Bacon prevailing wage requirements, which is held by the same prime contractor so much of the accrued payments or advances as may be considered necessary to pay laborers and mechanics, including apprentices, trainees and helpers, employed by the contractor or any subcontractor the full amount of wages required by the contract In the event of failure to pay any laborer or mechanic, including any apprentice, trainee or helper, employed or working on the site of the work, all or part of the wages required by the contract, HUD or its designee may, after written notice to the contractor, sponsor, applicant, or owner, take such action as may be necessary to cause the suspension of any further payment, advance, or guarantee of funds until such violations have ceased. HUD or its designee may, after written notice to the contractor, disburse such amounts withheld for and on account of the contractor or subcontractor to the respective employees to whom they are due. The Comptroller General shall make such disbursements in the case of direct Davis-Bacon Act contracts.

3. (i) Payrolls and basic records. Payrolls and basic records relating thereto shall be maintained by the contractor during the course of the work preserved for a period of three years thereafter for all laborers and mechanics working at the site of the work. Such records shall contain the name, address, and social security number of each such worker, his or her correct classification, hourly rates of wages paid (including rates of contributions or costs anticipated for bona fide fringe benefits or cash equivalents thereof of the types described in Section I(b)(2)(B) of the Davis-bacon Act), daily and weekly number of hours worked, deductions made and actual wages paid. Whenever the Secretary of Labor has found under 29 CFR 5.5 (a)(1)(iv) that the wages of any laborer or mechanic include the amount of any costs reasonably anticipated in providing benefits under a plan or program described in Section I(b)(2)(B) of the Davis-Bacon Act, the contractor shall maintain records which show that the commitment to provide such benefits is enforceable, that the plan or program is financially responsible, and that the plan or program has been communicated in writing to the laborers or mechanics affected, and records which show the costs anticipated or the actual cost incurred in providing such benefits. Contractors employing apprentices or trainees under approved programs shall maintain written evidence of the registration of apprenticeship programs and certification of trainee programs, the registration of the apprentices and trainees, and the ratios and wage rates prescribed in the applicable programs. (Approved by the Office of Management and Budget under OMB Control Numbers 1215-0140 and 1215-0017.)

(ii) (a) The contractor shall submit weekly for each week in which any contract work is performed a copy of all payrolls to HUD or its designee if the agency is a party to the contract, but if the agency is not such a party, the contractor will submit the payrolls to the applicant sponsor, or owner, as the case may be, for transmission to HUD or its designee. The payrolls submitted shall set out accurately and completely all of the information required to be maintained under 29 CFR 5.5(a)(3)(i) except that full social security numbers and home addresses shall not be included on weekly transmittals. Instead the payrolls shall only need to include an individually identifying number for each employee (e.g., the last four digits of the employee's social security number). The required weekly payroll information may be submitted in any form desired. Optional Form WH-347 is available for this purpose from the Wage and Hour Division Web site at <http://www.dol.gov/esa/whd/forms/wh347instr.htm> or its successor site. The prime contractor is

responsible for the submission of copies of payrolls by all subcontractors. Contractors and subcontractors shall maintain the full social security number and current address of each covered worker, and shall provide them upon request to HUD or its designee if the agency is a party to the contract, but if the agency is not such a party, the contractor will submit the payrolls to the applicant sponsor, or owner, as the case may be, for transmission to HUD or its designee, the contractor, or the Wage and Hour Division of the Department of Labor for purposes of an investigation or audit of compliance with prevailing wage requirements. It is not a violation of this subparagraph for a prime contractor to require a subcontractor to provide addresses and social security numbers to the prime contractor for its own records, without weekly submission to HUD or its designee. (Approved by the Office of Management and Budget under OMB Control Number 1215-0149.)

(b) Each payroll submitted shall be accompanied by a "Statement of Compliance," signed by the contractor or subcontractor or his or her agent who pays or supervises the payment of the persons employed under the contract and shall certify the following:

(1) That the payroll for the payroll period contains the information required to be provided under 29 CFR 5.5 (a)(3)(ii), the appropriate information is being maintained under 29 CFR 5.5(a)(3)(i), and that such information is correct and complete; Previous editions are obsolete Page 3 of 5 form **HUD-4010** (06/2009) ref. Handbook 1344.1 **(2)** That each laborer or mechanic (including each helper, apprentice, and trainee) employed on the contract during the payroll period has been paid the full weekly wages earned, without rebate, either directly or indirectly, and that no deductions have been made either directly or indirectly from the full wages earned, other than permissible deductions as set forth in 29 CFR Part 3;

(3) That each laborer or mechanic has been paid not less than the applicable wage rates and fringe benefits or cash equivalents for the classification of work performed, as specified in the applicable wage determination incorporated into the contract.

(c) The weekly submission of a properly executed certification set forth on the reverse side of Optional Form WH-347 shall satisfy the requirement for submission of the "Statement of Compliance" required by subparagraph A.3.(ii)(b).

(d) The falsification of any of the above certifications may subject the contractor or subcontractor to civil or criminal prosecution under Section 1001 of Title 18 and Section 231 of Title 31 of the United States Code.

(iii) The contractor or subcontractor shall make the records required under subparagraph A.3.(i) available for inspection, copying, or transcription by authorized representatives of HUD or its designee or the Department of Labor, and shall permit such representatives to interview employees during working hours on the job. If the contractor or subcontractor fails to submit the required records or to make them available, HUD or its designee may, after written notice to the contractor, sponsor, applicant or owner, take such action as may be necessary to cause the suspension of any further payment, advance, or guarantee of funds. Furthermore, failure to submit the required records upon request or to make such records available may be grounds for debarment action pursuant to 29 CFR 5.12.

4. Apprentices and Trainees.

(i) Apprentices. Apprentices will be permitted to work at less than the predetermined rate for the work they performed when they are employed pursuant to and individually registered in a bona fide apprenticeship program registered with the U.S. Department of Labor, Employment and Training Administration, Office of Apprenticeship Training, Employer and Labor Services, or with a State Apprenticeship Agency recognized by the Office, or if a person is employed in his or her first 90 days of probationary employment as an apprentice in such an apprenticeship program, who is not individually registered in the program, but who has been certified by the Office of Apprenticeship Training, Employer and Labor Services or a State Apprenticeship Agency (where appropriate) to be eligible for probationary employment as an apprentice. The allowable ratio of apprentices to journeymen on the job site in any craft classification shall not be greater than the ratio permitted to the contractor as to the entire work force under the registered program. Any worker listed on a payroll at an apprentice wage rate, who is not registered or otherwise employed as stated above, shall be paid not less than the applicable wage rate on the wage determination for the classification of work actually performed. In addition, any apprentice performing work on the job site in excess of the ratio permitted under the registered program shall be paid not less than the applicable wage rate on the wage determination for the work actually performed. Where a contractor is performing construction on a project in a locality other than that in which its program is registered, the ratios and wage rates (expressed in percentages of the journeyman's hourly rate) specified in the contractor's or subcontractor's registered program shall be observed. Every apprentice

must be paid at not less than the rate specified in the registered program for the apprentice's level of progress, expressed as a percentage of the journeymen hourly rate specified in the applicable wage determination. Apprentices shall be paid fringe benefits in accordance with the provisions of the apprenticeship program. If the apprenticeship program does not specify fringe benefits, apprentices must be paid the full amount of fringe benefits listed on the wage determination for the applicable classification. If the Administrator determines that a different practice prevails for the applicable apprentice classification, fringes shall be paid in accordance with that determination. In the event the Office of Apprenticeship Training, Employer and Labor Services, or a State Apprenticeship Agency recognized by the Office, withdraws approval of an apprenticeship program, the contractor will no longer be permitted to utilize apprentices at less than applicable predetermined rate for the work performed until an acceptable program is approved.

(ii) Trainees. Except as provided in 29 CFR 5.16, trainees will not be permitted to work at less than the predetermined rate for the work performed unless they are employed pursuant to and individually registered in a program which has received prior approval, evidenced by formal certification by the U.S. Department of Labor, Employment and Training Administration. The ratio of trainees to journeymen on the job site shall not be greater than permitted under the plan approved by the Employment and Training Administration. Every trainee must be paid at not less than the rate specified in the approved program for the trainee's level of progress, expressed as a percentage of the journeyman hourly rate specified in the applicable wage determination. Trainees shall be paid fringe benefits in accordance with the provisions of the trainee program. If the trainee program does not mention fringe benefits, trainees shall be paid the full amount of fringe benefits listed on the wage determination unless the Administrator of the Wage and Hour Division determines that there is an apprenticeship program associated with the corresponding journeyman wage rate on the wage determination which provides for less than full fringe benefits for apprentices. Any employee listed on the payroll at a trainee rate who is not registered and participating in a training plan approved by Previous editions are obsolete Page 4 of 5 form **HUD-4010** (06/2009) ref. Handbook 1344.1 the Employment and Training Administration shall be paid not less than the applicable wage rate on the wage determination for the work actually performed. In addition, any trainee performing work on the job site in excess of the ratio permitted under the registered program shall be paid not less than the applicable wage rate on the wage determination for the work actually performed. In the event the Employment and Training Administration withdraws approval of a training program, the contractor will no longer be permitted to utilize trainees at less than the applicable predetermined rate for the work performed until an acceptable program is approved.

(iii) Equal employment opportunity. The utilization of apprentices, trainees and journeymen under 29 CFR Part 5 shall be in conformity with the equal employment opportunity requirements of Executive Order 11246, as amended, and 29 CFR Part 30.

5. Compliance with Copeland Act requirements. The contractor shall comply with the requirements of 29 CFR Part 3 which are incorporated by reference in this contract

6. Subcontracts. The contractor or subcontractor will insert in any subcontracts the clauses contained in subparagraphs 1 through 11 in this paragraph A and such other clauses as HUD or its designee may by appropriate instructions require, and a copy of the applicable prevailing wage decision, and also a clause requiring the subcontractors to include these clauses in any lower tier subcontracts. The prime contractor shall be responsible for the compliance by any subcontractor or lower tier subcontractor with all the contract clauses in this paragraph.

7. Contract termination; debarment. A breach of the contract clauses in 29 CFR 5.5 may be grounds for termination of the contract and for debarment as a contractor and a subcontractor as provided in 29 CFR 5.12.

8. Compliance with Davis-Bacon and Related Act Requirements. All rulings and interpretations of the Davis-Bacon and Related Acts contained in 29 CFR Parts 1, 3, and 5 are herein incorporated by reference in this contract

9. Disputes concerning labor standards. Disputes arising out of the labor standards provisions of this contract shall not be subject to the general disputes clause of this contract. Such disputes shall be resolved in accordance with the procedures of the Department of Labor set forth in 29 CFR Parts 5, 6, and 7. Disputes within the meaning of this clause include disputes between the contractor (or any of its subcontractors) and HUD or its designee, the U.S. Department of Labor, or the employees or their representatives.

10. (i) Certification of Eligibility. By entering into this contract the contractor certifies that neither it (nor he or she) nor any person or firm who has an interest in the contractor's firm is a person or firm ineligible to be awarded Government contracts by virtue of Section 3(a) of the Davis-Bacon Act or 29 CFR 5.12(a)(1) or to be awarded HUD contracts or participate in HUD programs pursuant to 24 CFR Part 24.

(ii) No part of this contract shall be subcontracted to any person or firm ineligible for award of a Government contract by virtue of Section 3(a) of the Davis-Bacon Act or 29 CFR 5.12(a)(1) or to be awarded HUD contracts or participate in HUD programs pursuant to 24 CFR Part 24.

(iii) The penalty for making false statements is prescribed in the U.S. Criminal Code, 18 U.S.C. 1001. Additionally, U.S. Criminal Code, Section 1010, Title 18, U.S.C., "Federal Housing Administration transactions", provides in part: "Whoever, for the purpose of . . . influencing in any way the action of such Administration . . . makes, utters or publishes any statement knowing the same to be false . . . shall be fined not more than \$5,000 or imprisoned not more than two years, or both."

11. Complaints, Proceedings, or Testimony by Employees. No laborer or mechanic to whom the wage, salary, or other labor standards provisions of this Contract are applicable shall be discharged or in any other manner discriminated against by the Contractor or any subcontractor because such employee has filed any complaint or instituted or caused to be instituted any proceeding or has testified or is about to testify in any proceeding under or relating to the labor standards applicable under this Contract to his employer.

B. Contract Work Hours and Safety Standards Act. The provisions of this paragraph B are applicable where the amount of the prime contract exceeds \$100,000. As used in this paragraph, the terms "laborers" and "mechanics" include watchmen and guards.

(1) Overtime requirements. No contractor or subcontractor contracting for any part of the contract work which may require or involve the employment of laborers or mechanics shall require or permit any such laborer or mechanic in any workweek in which the individual is employed on such work to work in excess of 40 hours in such workweek unless such laborer or mechanic receives compensation at a rate not less than one and one-half times the basic rate of pay for all hours worked in excess of 40 hours in such workweek.

(2) Violation; liability for unpaid wages; liquidated damages. In the event of any violation of the clause set forth in subparagraph (1) of this paragraph, the contractor and any subcontractor responsible therefor shall be liable for the unpaid wages. In addition, such contractor and subcontractor shall be liable to the United States (in the case of work done under contract for the District of Columbia or a territory, to such District or to such territory), for liquidated damages. Such liquidated damages shall be computed with respect to each individual laborer or mechanic, including watchmen and guards, employed in violation of the clause set forth in subparagraph (1) of this paragraph, in the sum of \$10 for each calendar day on which such individual was required or permitted to work in excess of the standard workweek of 40 hours without payment of the overtime wages required by the clause set forth in subparagraph (1) of this paragraph. Previous editions are obsolete Page 5 of 5 form **HUD-4010** (06/2009) ref. Handbook 1344.1

(3) Withholding for unpaid wages and liquidated damages. HUD or its designee shall upon its own action or upon written request of an authorized representative of the Department of Labor withhold or cause to be withheld, from any moneys payable on account of work performed by the contractor or subcontractor under any such contract or any other Federal contract with the same prime contract, or any other Federally-assisted contract subject to the Contract Work Hours and Safety Standards Act which is held by the same prime contractor such sums as may be determined to be necessary to satisfy any liabilities of such contractor or subcontractor for unpaid wages and liquidated damages as provided in the clause set forth in subparagraph (2) of this paragraph.

(4) Subcontracts. The contractor or subcontractor shall insert in any subcontracts the clauses set forth in subparagraph (1) through (4) of this paragraph and also a clause requiring the subcontractors to include these clauses in any lower tier subcontracts. The prime contractor shall be responsible for compliance by any subcontractor or lower tier subcontractor with the clauses set forth in subparagraphs (1) through (4) of this paragraph.

C. Health and Safety. The provisions of this paragraph C are applicable where the amount of the prime contract exceeds \$100,000.

(1) No laborer or mechanic shall be required to work in surroundings or under working conditions which are unsanitary, hazardous, or dangerous to his health and safety as determined under construction safety and health standards promulgated by the Secretary of Labor by regulation.

(2) The Contractor shall comply with all regulations issued by the Secretary of Labor pursuant to Title 29 Part 1926 and failure to comply may result in imposition of sanctions pursuant to the Contract Work Hours and Safety Standards Act, (Public Law 91-54, 83 Stat 96). 40 USC 3701 et seq.

(3) The contractor shall include the provisions of this paragraph in every subcontract so that such provisions will be binding on each subcontractor. The contractor shall take such action with respect to any subcontractor as the Secretary of Housing and Urban Development or the Secretary of Labor shall direct as a means of enforcing such provisions.

Personnel and Participant Conditions

PERSONNEL AND PARTICIPANT CONDITIONS

1. **Non-Discrimination.** In accordance with Section 109 of the Housing and Community Development Act of 1974, no person in the United States shall on the ground of race, color, religion, natural origin, or sex, be excluded from participation in, be denied the benefits of, or be subjected to discrimination under, any program or activity funded in whole or in part with CDBG funds. Bidder shall comply with 42 U.S.C. §5309, et. seq., 24 CFR §570.602 and 24 CFR Part 6. Bidder shall at all times comply with sections 104(b), 107 and 109 of the Housing and Community Development Act of 1974, as amended; Title VI of the Civil Rights Act of 1964 (42 U.S.C. §2000d, et seq.); and implementing regulations in 24 CFR Part 1. HUD's Title VI regulations specify types of prohibited discrimination. Bidder must not, for example, based on race, color, or national origin deny a person housing or services; provide different housing or services than those provided others; subject a person to segregation or separate treatment in the receipt of housing or services; use different admission or eligibility requirements for housing or services; or select a housing site or location with the purpose or effect of excluding or denying benefits to persons in protected classes.

Bidder shall also not discriminate on the basis of age under the Age Discrimination Act of 1975 (42 U.S.C. §6101, et. seq.) and the implementing regulations contained in 24 CFR Part 146, or on the basis of disability as provided in Section 504 of the Rehabilitation Act of 1973, and the implementing regulations contained in 24 CFR Part 8. Any contracts entered into by Lighthouse shall include a provision for compliance with these regulations. Bidder shall keep records and documentation demonstrating compliance with these regulations.

2. **Equal Employment Opportunity.** Bidder shall comply with 24 CFR §570.607, Executive Order 11246, as amended by Executive Orders 11375, 11478, 12086, and 12107 (Equal Employment Opportunity), and Executive Order 13279 (Equal Protection of the Laws for Faith Based Community Organizations) and the implementing regulations in 41 CFR Part 60, and the provisions of the Equal Employment Opportunity Clause. Any contracts entered into by Bidder shall include a provision for requiring compliance with these regulations and will, in all solicitations or advertisements for employees state that is an Equal Opportunity/Affirmative Action employer. Bidder shall keep records and documentation demonstrating compliance with these regulations.

3. **Compliance with Davis-Bacon Act.** Bidder shall comply with 24 CFR §570.603, and the requirements of the Secretary of Labor in accordance with the Davis-Bacon Act (40 U.S.C. §276(a) to (a-7)), as amended, and as supplemented by Department of Labor regulation 29 CFR Part 5. Any construction contracts entered into by Bidder shall include a provision for compliance with the Davis-Bacon Act and supporting Department of Labor regulations. Bidder shall also place a copy of the current prevailing wage determination issued by the Department of Labor in each solicitation and the award of the contract shall be conditioned upon the acceptance of the wage determination. If the attached Wage decision is no longer current at the time of contracting, Bidder must ensure that a current copy is used. Bidder shall ensure that a current copy of the Wage Decision and a copy of the Department of Labor poster called "Notice to All Employees" (Form WH-1521) shall be posted at the jobsite in a place that is easily accessible to all of the construction workers employed on the Project. Bidder shall also require the contractor to obtain weekly certified payroll reports. Bidder shall maintain documentation and records which demonstrate compliance with these regulations, including contract provisions and payroll records. Unless labor regulations require more frequent submission, such documentation shall be submitted to the City for review on a monthly basis.

4. **Copeland "Anti-Kickback" Act.** Bidder shall comply with the Copeland "Anti-Kickback" Act (18 U.S.C. §874) as supplemented by the Department of Labor regulations contained in 29 CFR Part 3. Any construction contracts entered into by Bidder shall include a provision for compliance with these regulations. Bidder shall maintain documentation and records which demonstrate compliance with these regulations. Such documentation shall be submitted to the City for review on a monthly basis.

5. Contract Work Hours and Safety Standards Act: Bidder agrees to comply with the Contract Work Hours and Safety Standards Act (40 U.S.C. §327-333), as supplemented by the Department of Labor regulations contained in 29 CFR Part 5. Any construction contracts entered into by Bidder shall include a provision for compliance with these regulations. Bidder shall maintain documentation and records which demonstrate compliance with these regulations. Such documentation shall be submitted to the City for review on a monthly basis.

6. Handicapped Accessibility Requirements. Bidder shall construct, and rehabilitate the Project so that it is accessible to and useable by individuals with handicaps, in compliance with the Architectural Barriers Act of 1968 (42 U.S.C. §§ 4151-4157), the Uniform Federal Accessibility Standards, as set forth in 24 CFR §570.614, the Americans with Disabilities Act of 1990 (42 U.S.C. §12131), Section 504 of the Rehabilitation Act of 1973 and the implementing regulations in 24 CFR Part 8, and all state and local laws requiring physical and program accessibility to people with disabilities. Any contracts entered into by Bidder shall include a provision for compliance with these regulations. Bidder shall keep records demonstrating compliance with these regulations.

7. Utilization of Minority/Women's Business Enterprises. Bidder will use its best efforts to ensure that minority/women's business enterprises are afforded the opportunity and included for consideration for participation in all construction, supply or service contracts or in the performance of this Agreement. Bidder shall comply with Executive Order 11625, as amended by Executive Order 12007 (Minority Business Enterprises); Executive Order 12432 (Minority Business Enterprise Development); and Executive Order 12138, as amended by Executive Order 12608 (Women's Business Enterprise). Any contracts entered into by Bidder shall include a provision for compliance with these regulations. Bidder shall keep records demonstrating compliance with this provision including the affirmative steps taken to assure that minority business and women's business enterprises have an equal opportunity to obtain or compete for contracts and subcontracts.

8. Political Activities. Bidder shall comply with 24 CFR §570.207(a)(3) regarding political activities. CDBG funds shall not be used for lobbying or political patronage activities. Bidder further agrees that no funds provided, nor personnel employed under this Agreement, shall be in any way or to any extent be engaged in the conduct of political activities in violation of Chapter 15 of Title V, United States Code (Hatch Act), or 24 CFR §570.207(a)(3).

9. Anti-Lobbying Provision. Bidder shall comply with the requirements set forth in 31 U.S.C. §1352 and implementing regulations at 24 CFR Part 87. Bidder and any contractors who apply or bid for an award of \$100,000 or more shall execute and comply with the "Certification Regarding Lobbying". Bidder shall execute the "Certification Regarding Lobbying" and a copy shall be kept in the files of each of the parties of this Agreement.

10. Conflict of Interest. In the procurement of supplies, equipment, construction and services, Bidder shall comply with the conflict of interest rules in 24 CFR §84.42. Bidder shall comply with the conflict of interest provisions contained in 24 CFR §570.611 for those cases not governed by §84.42. Such cases include the acquisition and disposition of real property and the provision of assistance by Bidder to individuals, businesses, and other private entities under eligible activities that authorize such assistance (i.e. rehabilitation).

Although this summary does not intend to replace 24 CFR §570.611, essentially this rule states that no "person" who exercised any functions or responsibilities with respect to activities assisted with CDBG funds or who is in a position to participate in a decision-making process or gain inside information with regard to these activities, may obtain a financial interest or benefit from a CDBG-assisted activity, or have a financial interest in any contract, subcontract or agreement with respect thereto, or the proceeds thereunder, either for themselves or those with whom they have family or business ties, during their tenure of for one year thereafter. "Person" includes employees, agents,

consultants, officers, elected officials, appointed officials, or of any designated public agencies or of subrecipients receiving CDBG funds. Bidder agrees that it will establish and adopt safeguards to prohibit members, officers, employees and the like from using positions for a purpose that is or gives the appearance of being motivated for private gain for themselves or others with whom they have family, business, or other ties. Bidder shall also keep records supporting requests for waivers of conflicts.

11. Section 3 of the Housing and Urban Development Act of 1968/Equal Opportunity.

Bidder shall comply with the provisions of Section 3 of the Housing and Urban Development Act of 1968 (12 U.S.C. §1701u) and its implementing regulations contained in 24 CFR Part 135 regarding economic opportunities for low income persons and the use of local businesses, if applicable. Bidder shall comply with the provisions of the “Section 3 Clause”, and require all subcontracts to contain a copy of the Section 3 clause. Bidder shall also keep records demonstrating compliance with these regulations, including 24 CFR §570.506(g)(5).

12. Faith-Based Activities.

(a) Equal treatment of program participants and program beneficiaries.

(1) Program participants. Organizations that are religious or faith-based are eligible, on the same basis as any other organization, to participate in the CDBG program. Neither the Federal Government or a State or local government receiving funds under the CDBG program shall discriminate against an organization on the basis of the organization’s religious character or affiliation.

(b) Separation of inherently religious activities. Organizations that are directly funded under the CDBG program may not engage in inherently religious activities, such as worship, religious instruction, or proselytization, as part of the programs or services funded. If an organization conducts such activities, the activities must be offered separately, in time or location, from the programs or services funded under this part, and participation must be voluntary for the program beneficiaries of the HUD-funded programs or services provided.

(c) Religious Identity. A religious organization that is a recipient or subrecipient of CDBG program funds will retain its independence from federal, state, and local governments, and may continue to carry out its mission, including the definition, practice, and expression of its religious beliefs, provided that it does not use direct CDBG funds to support any inherently religious activities, such as worship, religious instruction, or proselytization. Among other things, faith-based organizations may use space in their facilities to provide CDBG-funded services, without removing or altering religious art, icons, scriptures, or other religious symbols. In addition, a CDBG-funded religious organization retains its authority over its internal governance, and it may retain religious terms in its organization’s name, select its board members on a religious basis, and include religious references in its organization’s mission statements and other governing documents.

(d) Beneficiaries. An organization that participates in the CDBG program shall not, in providing program assistance, discriminate against a program beneficiary or prospective program beneficiary on the basis of religion or religious belief. (e) Structures. CDBG funds may not be used for the acquisition, construction, or rehabilitation of structures to the extent that those structures are used for inherently religious activities. CDBG funds may be used for the acquisition, construction, or rehabilitation of structures only to the extent that those structures are used for conducting eligible activities under this part. Where a structure is used for both eligible and inherently religious activities, CDBG funds may not exceed the cost of those portions of the acquisition, new construction, or rehabilitation that are attributable to eligible activities in accordance with the cost accounting requirements applicable to CDBG funds. Sanctuaries, chapels, or other rooms that a CDBG-funded religious congregation uses as its principal place of worship, however, are ineligible for CDBG - funded improvements. Disposition of the real property after the term of the loan or grant, or any change in use of the property during the term of the grant or loan, is subject to government wide regulations governing real property disposition (24 CFR parts 84 and 85).

13. **Drug Free Workplace.** Bidder will provide a drug-free workplace. Bidder shall comply with the Drug-Free Workplace Act of 1988 and implementing regulations in 2 CFR Part 2429 regarding maintenance of a drug-free workplace. Lighthouse shall complete and comply with the "Certification Regarding Drug-Free Workplace Requirements". Bidder will complete this certification and a copy shall be kept in the files of each of the parties of this Agreement.

14. **Program Requirements.** Bidder agrees to comply and carry out all of its activities in accordance with the program requirements set forth in 24 CFR 570, subpart K.

15. **Fair Housing Act and Nondiscrimination and Equal Opportunity in Housing under E.O. 11063.** Bidder shall comply with the Fair Housing Act (42 U.S.C. §§3601-3620) and implementing regulations at 24 CFR Part 100, Executive Order 11063, as amended by Executive Order 12259 (Equal Opportunity in Housing) and their implementing regulations in 24 CFR Part 107 and shall keep records demonstrating compliance with this provision.

16. **Resident Aliens.** Bidder shall comply with the requirements set forth in 24 CFR §570.613 regarding eligibility restrictions for certain resident aliens.

17. **Debarment and Suspension.** Bidder shall comply with the debarment and suspension requirements set forth in 24 CFR §570.609, which requires compliance with 24 CFR Part 5 and 2 CFR Part 2424. Bidder shall not enter into a contract with any person, agency or entity that is debarred, suspended or otherwise excluded from or ineligible for participation in federal assistance programs under Executive Order 12549 or 12689, "Debarment and Suspension," which is made a part of this Agreement by reference. In the event that Bidder has entered into a contract or subcontract with a debarred or suspended party, no CDBG funds will be provided as reimbursement for the work done by that debarred or suspended contractor or subcontractor. Bidder shall keep copies of the debarment and suspension certifications required by 2 CFR Parts 2424 and a copy of the sheet documenting that the federal debarment list was checked.

18. **Building, Zoning, and Permits.** Bidder agrees to comply with all laws of the State of Florida and the Orlando City Code. In particular, Bidder shall comply with all applicable building and zoning laws and regulations and obtain all necessary permits for intended improvements or activities for the Project.

Labor Retention Letter



Office of Labor Relations
LABOR RELATIONS LETTERS

Date: October 26, 2006 (Rev 1)

Letter No. LR 2004-01

- Subject: Administration and enforcement of prevailing wage rates determined or adopted by HUD**
- I. Statutory provisions and prior guidance**
 - II. Elimination of payroll certification and submission, payroll deduction and weekly wage payment requirements**
 - III. Recordkeeping requirements**
 - IV. Payroll deductions and frequency of wage payments**
 - V. Labor standards clauses for routine and non-routine maintenance contracts**
 - VI. Compliance monitoring**

The Department of Housing and Urban Development (HUD) has undertaken efforts to streamline and otherwise reform its policies and instructions relating to the administration and enforcement of prevailing wage rates determined or adopted by HUD (*aka* HUD-determined wage rates). Ultimately, HUD intends to publish regulations and other formal directives relating to these areas. The purpose of this Letter is to provide relief and interim guidance for public housing authorities (PHAs), tribes, tribally designated housing entities (TDHEs), and their contractors. Note that the guidance in this Letter pertains only to HUD-determined wage rates applicable to maintenance and non-routine maintenance. This guidance does **not** pertain to construction work subject to Davis-Bacon and Related Act wage and reporting requirements.

This guidance is provided with the cooperation and advice of the Offices of Public and Indian Housing, Native American Programs, and General Counsel.

I. Statutory provisions and prior guidance

HUD prevailing wage requirements are imposed at Section 12(a) of the U.S. Housing Act of 1937, as amended, for public housing and at Section 104(b) and 805(b) of the Native American Housing Assistance and Self-Determination Act of 1996, as amended, for Indian housing and Native Hawaiian housing, respectively. Generally, these clauses require, in part, that all maintenance laborers and mechanics employed in the operation of the housing

project (which includes routine and non-routine maintenance work) be paid no less than the wage rates prevailing in the locality as determined or adopted (subsequent to a determination under applicable State, local or tribal law) by HUD.¹

In developing its operational policies and procedures for these areas of responsibility, HUD relied upon the framework established by the Department of Labor (DOL) for the Davis-Bacon and Related Acts (DBRA). HUD disseminated its policies and procedures in draft Notice 95-01-SL and in associated memoranda, contract standards, training materials and other communications.

DBRA standards are similar to those associated with HUD prevailing wage requirements, but in some cases are more stringent. HUD has discretion to establish policies and procedures for HUD-determined wage rates different from the DOL DBRA standards. HUD has concluded that it is reasonable and desirable to establish a prevailing wage administration and enforcement framework for HUD-determined wage rates that is less burdensome on PHAs, TDHEs, tribes and their contractors.

II. Elimination of payroll certification and submission, payroll deduction and weekly wage payment requirements

Prior HUD guidance required contractors and/or subcontractors performing work subject to HUD-determined wage rates to submit weekly certified payroll reports to the PHA, tribe or TDHE involved, and to comply with DOL regulations at 29 CFR Part 3 concerning permissible payroll deductions. In addition, HUD required that all laborers and mechanics (covered by HUD-determined wage rates) be paid not less often than once a week. These requirements were contained in the draft Notice 95-01-SL and in HUD Form 5370, General Conditions (for non-routine maintenance). Effective immediately, HUD is amending its guidance and HUD Form 5370 to eliminate the payroll certification and submission and weekly wage payment requirements.²

Note that with regard to records, the HUD is eliminating only the requirements to certify and submit payroll reports. This action does not relieve contractors and/or subcontractors of

¹ Note that under NAHASDA, HUD-determined wage rates may be preempted by tribally determined prevailing wage rates; see ONAP Program Guidance No. 2003-04. Additionally, bona fide volunteers are excluded from HUD prevailing wage requirements; see 24 CFR Part 70.

² Following consultation with the Department of Labor, HUD has concluded that DOL regulations at 29 CFR Parts 3 and 5 are not germane where HUD prevailing wage requirements are applicable.

their obligations to create and maintain records demonstrating their compliance with HUD-determined prevailing wage requirements.

See Sections III and IV of this Letter concerning recordkeeping, payroll deduction and pay frequency requirements.

III. Recordkeeping requirements

PHAs, tribes, TDHEs, and any other employers (e.g., contractors, subcontractors) engaged on work subject to HUD-determined wage rates must make and maintain for 3 years from the completion of the work records containing information demonstrating compliance with the prevailing wage rates determined (or adopted) by HUD and applicable to the work.³ These records must at a minimum contain for each laborer and mechanic employed:

- 1) His or her name, address and social security number;
- 2) Correct work classification or classifications;
- 3) Hourly rate or rates of monetary wages paid;
- 4) Rate or rates of any fringe benefits provided;
- 5) Number of daily and weekly hours worked;
- 6) Gross wages earned;
- 7) Any deductions taken; and
- 8) Actual wages paid.

Such records shall be made available for inspection or transcription by authorized representatives of the PHA, tribe, TDHE and/or HUD.

IV. Payroll deductions and frequency of wage payments

Employers (PHAs, tribes, TDHEs, contractors and/or subcontractors) must pay to each employee subject to HUD-determined wage requirements the full amount of wages due free and clear and without subsequent deduction (except as otherwise provided by law or regulations). These payments must be made no later than one pay period following the end of the regular pay period in which the wages were earned or accrued. A pay period may not be of any duration longer than semi-monthly.

³ The recordkeeping burden reflected is required by DOL and approved by the Office of Management and Budget under control number 1215-0017.

V. Labor standards clauses for routine and non-routine maintenance contracts

PHAs, tribes and TDHEs that award contracts for routine or non-routine maintenance work must incorporate into the contract (and bid specifications, if applicable) appropriate labor standards clauses to obligate and ensure the compliance of the contractor and any subcontractors. HUD has published labor standards clauses applicable to routine and non-routine maintenance in HUD Form 5370-C, General Conditions for Non-Construction Contracts, Section II⁴. The applicable HUD wage decision must also be incorporated into the contract and any bid specifications.

VI. Compliance monitoring and employee interviews

PHAs, tribes and TDHEs shall perform contractor compliance monitoring with such frequency and depth as appropriate (based upon the scope and duration of the contract involved) to ensure that all laborers and mechanics are paid no less than the HUD prevailing wage rate for the type of work they perform. Such compliance monitoring shall include interviews with the employees. Contractors and/or subcontractors shall permit authorized representatives of the PHA, tribe, TDHE or HUD to interview employees during normal working hours.

Any questions regarding this Letter should be directed to the field or Regional HUD Labor Relations staff responsible for the jurisdiction involved. A list of Labor Relations staff and contact information is available at the Office of Labor Relations website:

www.hud.gov/offices/olr

/S/

Edward L. Johnson

Director

Office of Labor Relations

⁴ Available at HUDClips (www.hudclips.org/cgi/index.cgi) and the Office of Labor Relations web site (www.hud.gov/offices/olr).